



# **WORKS WITHIN ROAD RESERVE MANUAL**

## **Standards and Requirements**

<b>Revision Number</b>	<b>Revision Date</b>	<b>Release Date</b>
Original		28 June 2012
Revision 1	22 January 2015	29 January 2015

# TABLE OF CONTENTS

---

<b>1. INTRODUCTION.....</b>	<b>1</b>
<b>2. LEGISLATION.....</b>	<b>2</b>
2.1 WATER CORPORATIONS .....	2
2.1.1 Section 133(2).....	2
2.1.2 Section 134(1).....	3
2.1.3 Section 137.....	3
2.1.4 Section 149.....	3
2.1.5 Section 155.....	4
2.2 ELECTRICITY CORPORATIONS.....	4
2.2.1 Section 93.....	4
2.3 GAS ORGANISATIONS.....	5
2.3.1 Section 148(1).....	5
2.3.2 Section 148(4).....	6
2.3.3 Section 148(5).....	6
2.3.4 Section 149.....	7
2.3.5 Section 149(3).....	7
2.4 TELECOMMUNICATIONS ORGANISATIONS.....	7
2.4.1 Clause 5 of Schedule 3 – Telecommunications Act.....	8
2.4.2 Clause 6(1) of Schedule 3 – Telecommunications Act.....	8
2.4.3 Clause 9 of Schedule 3 – Telecommunications Act.....	9
2.4.4 Clause 10 of Schedule 3 – Telecommunications Act.....	9
2.4.5 Clause 19(1) of Schedule 3 – Telecommunications Act.....	9
2.4.6 Clause 42(1) & (2) of Schedule 3 – Telecommunications Act.....	9
2.4.7 Clause 43 of Schedule 3 – Telecommunications Act.....	10
2.4.8 Clause 3.1(2) – Telecommunications (Low-Impact Facilities) Determination.....	10
2.4.9 Clause 2.3 – Telecommunications Code of Practice.....	11
2.4.10 Clause 2.4 – Telecommunications Code of Practice.....	11
2.4.11 Clause 2.5 – Telecommunications Code of Practice.....	11
<b>3. GENERAL REQUIREMENTS .....</b>	<b>13</b>
3.1 CONSENT FOR WORKS .....	13
3.2 NOTIFICATION OF WORKS.....	13
3.3 NOTIFICATION OF EMERGENCY WORKS.....	13
3.4 PUBLIC SAFETY.....	14
3.5 PROVISION FOR TRAFFIC .....	14
3.6 HOURS OF WORK.....	15
3.7 UTILITY COMPANY REPRESENTATIVES.....	15
3.8 PUBLIC NOTIFICATION OF WORKS .....	13
3.9 SITE OFFICES.....	15
3.10 DAMAGE TO COUNCIL INFRASTRUCTURE.....	15
3.10.1 Clause 55 - Damage To Road And Other Infrastructure.....	15
3.10.2 Clause 59 - Failure Of Utility Infrastructure In Road Reserves.....	16
3.11 ENVIRONMENTAL AND CULTURAL HERITAGE PROTECTION ZONES.....	16
<b>4. CONSTRUCTION REQUIREMENTS.....</b>	<b>17</b>
4.1 LOCATING INFRASTRUCTURE IN THE ROAD RESERVE .....	17
4.1.1 Aerial Infrastructure – Position and Height Clearance.....	17
4.1.2 Underground Infrastructure - Arterial Roads (Appendix B).....	17
4.1.3 Underground Infrastructure - Municipal Roads.....	17
4.1.4 Underground Infrastructure - Public Pathways and Roadsides.....	18
4.2 REMOVAL OF SPOIL.....	18
4.3 STOCKPILING MATERIAL.....	19

4.4	CONDUITS .....	19
4.4.1	Colour of Conduit – Hazardous Service.....	19
4.4.2	Colour of Conduit – Telecommunications Service .....	20
4.5	INSTALLING INFRASTRUCTURE UNDER ROADWAYS .....	20
4.5.1	Boring.....	20
4.5.2	Excavation .....	20
4.6	EXCAVATION NEAR TREES .....	21
4.6.1	Background .....	21
4.6.2	Tree Roots.....	21
4.6.3	Works Relating to Utility Companies .....	23
4.6.4	Other Works Within Road Reserves Affecting Trees, Shrubs, and Indigenous Vegetation .....	24
4.6.5	Branches Obstructing Works.....	24
4.6.6	Removal of Trees by Utility Company.....	25
<b>5.</b>	<b>REINSTATEMENT OF WORK AREA .....</b>	<b>26</b>
5.1	MATERIALS .....	26
5.1.1	Class 2 and Class 3 FCR.....	26
5.2	BEDDING.....	26
5.3	BACKFILLING .....	26
5.3.1	Conduits under Unpaved Areas.....	27
5.3.2	Conduits under Existing Paved Areas including Shoulders and Verges .....	27
5.4	COMPACTION STANDARDS .....	27
5.4.1	Bedding and backfill (except pavement).....	27
5.4.2	Pavement .....	27
5.5	COMPACTION EQUIPMENT.....	27
5.5.1	Vibrating Plate Compactors.....	27
5.5.2	Tamping Rammers.....	28
5.6	TESTING .....	29
5.6.1	Bedding and backfill (except pavement).....	29
5.6.2	Pavement .....	29
5.7	REINSTATEMENT QUALITY ASSURANCE.....	29
5.8	MAINTENANCE.....	29
5.9	FINISHED SURFACE REINSTATEMENT .....	30
5.10	TIMING OF REINSTATEMENTS .....	30
5.11	TEMPORARY REINSTATEMENTS .....	30
5.12	EXTENT OF REINSTATEMENTS .....	31
5.12.1	Roads.....	31
5.12.2	Footpaths and Driveways.....	32
5.12.3	Kerb and Channel.....	32
5.13	PRE-CUTTING OF WORKS .....	33
5.14	STREET FURNITURE.....	33
5.15	ROAD OPENING LIABILITY.....	33
5.16	FAILURE TO COMPLY .....	34
5.17	PERMITS REQUIRED UNDER LOCAL LAW .....	34
5.18	EXEMPTION FROM PERMITS REQUIRED UNDER LOCAL LAW .....	35
5.19	SPECIAL CIRCUMSTANCES.....	35
<b>6.</b>	<b>COUNCIL'S STANDARDS .....</b>	<b>36</b>
6.1	ROADSIDES .....	36
6.1.1	Definition.....	36
6.2	PATHWAYS.....	37
6.2.1	Gravel.....	37
6.2.2	Asphalt.....	38
6.2.3	Concrete .....	39
6.3	KERB AND CHANNEL.....	40
6.3.1	Concrete & Bluestone Channel .....	40
6.4	PROPERTY STORMWATER DRAINS .....	41
6.4.1	P.V.C. ....	41
6.4.2	Earthenware .....	42
6.5	DRIVEWAYS .....	42
6.5.1	Gravel.....	42

6.5.2	Asphalt.....	43
6.5.3	Concrete.....	43
6.6	ROAD SHOULDERS .....	45
6.6.1	Sealed.....	45
6.6.2	Unsealed.....	45
6.7	ROADWAYS .....	46
6.7.1	Sealed.....	46
6.7.2	Unsealed.....	47
<b>APPENDICES.....</b>		<b>48</b>
6.8	APPENDIX A – INFRASTRUCTURE DESIGN MANUAL.....	48
6.9	APPENDIX B - DECLARED ROADS LIST .....	49
6.10	APPENDIX C - ASPHALT SELECTION GUIDE .....	55
6.11	APPENDIX D – BLUESTONE PITCHER CHANNEL .....	57
6.12	APPENDIX E – BLUESTONE KERB AND CONCRETE CHANNEL (MAJOR WORKS).....	59
6.13	APPENDIX F – BLUESTONE KERB AND CHANNEL (MINOR WORKS) .....	61
6.14	APPENDIX G – VEHICLE CROSSINGS BLUESTONE KERB AND CHANNEL .....	63
6.15	APPENDIX H – PEDESTRIAN CROSSING BLUESTONE KERB AND CHANNEL .....	65
6.16	APPENDIX I – MAIN ROAD PAVEMENT REINSTATEMENT.....	67

## 1. INTRODUCTION

Municipal roads (including pathways (footpaths)) are key assets under the management and control of the City of Greater Geelong.

A number of statutory authorities and private organisations are responsible for utility assets, such as cables and pipes, that run in, under and over municipal roads. Such utilities include: Telstra, Optus, Powercor, Barwon Water, and SPI Networks. They require access to their assets from time to time in order to service or upgrade them.

In order to access their various assets, it is necessary for the utilities to open the municipal road, and when work is completed, any opening must be made 'good'. Making 'good' requires that any material used for filling and its subsequent compaction must be compatible with the surrounding material to ensure that the structural integrity of the municipal road is maintained. If the opening has been in a sealed roadway or pathway, the final seal must also be of the same type as the surface surrounding the opening, unless otherwise approved. All work must be to the satisfaction of Council by way of adopted standards.

It is apparent that there is a limited understanding of the standards for Municipal road reinstatements which is resulting in poor quality workmanship being conducted by those carrying out the work and those responsible for overseeing the work.

This document sets out the standards and requirements that Council has developed in relation to carrying out of works on municipal roads by utility organisations when it comes to installing, maintaining and inspecting their infrastructure in municipal roads. All works undertaken by utilities for installation, maintenance, inspection of their assets, must comply with this document as well as Council's Road Management Plan, the *Road Management Act 2004* and the applicable Codes of Practice made pursuant to the *Road Management Act*.

## 2. LEGISLATION

Most utility organisations operate under an Act of Parliament (eg Barwon Water under the *Water Act 1989*) These Acts impose obligations on the organisation for the carrying out of works within areas of land and/or affecting assets owned by other authorities or private entities.

In general, however these organisations are subject to the *Road Management Act 2004*. This Act prevails over all other Acts to the extent of any inconsistency (including local laws) unless the contrary is stated.

The utility organisations are also subject to a range of other Acts which may have an impact on if and how they can carry out works on a municipal road. This legislation includes the:

- Environmental Protection Act 1970 (Vic)
- Local Government Act 1989 (Vic)
- Heritage Act 1995 (Vic)
- Aboriginal Heritage Act 2006 (Vic)
- Mines Act 1958 (Vic)
- Planning and Environment Act 1987
- Environmental Protection and Biodiversity Conservation Act 1999 (Cth)

### 2.1 WATER CORPORATIONS

The powers and responsibilities of Barwon Water and other associated water corporations including their contractors are set out in the *Water Act 1989* (Vic).

The main sections of the *Water Act 1989* relevant to carrying out works on municipal roads are sections 133(2), 134(1), 137, 149 and 155.

#### 2.1.1 Section 133(2)

Under section 133(2) of the *Water Act 1989*, an officer of an Authority (which includes a water corporation) or an authorised person may enter any land for the purpose of carrying out any works it is empowered to carry out under the *Water Act 1989*.

When exercising a right under section 133(2) of the *Water Act 1989*, a water authority or authorised person must:

- (a) comply with the obligations set out in section 134(1) of that Act (see below); and
- (b) give seven days' prior notice to the "occupier" of the land.

### 2.1.2 Section 134(1)

Section 134(1) of the *Water Act 1989* provides that:

In exercising the powers given by section 133, an officer or authorised person must –

- (a) cause as little harm and inconvenience as possible; and
- (b) not stay on the land for any longer than is reasonably necessary; and
- (c) remove from the land on completing the works all plant, machinery, equipment, goods or temporary buildings brought onto the land by the officer or authorised person, other than anything that the owner or occupier of the land agrees may be left there; and
- (d) leave the land as nearly as possible in the condition in which he or she found it; and
- (e) co-operate as much as possible with the owner and occupier of the land.

### 2.1.3 Section 137

Section 137 of the *Water Act 1989* states that subject to the *Road Management Act 2004*, an Authority may enter upon any public or private land or road for the purpose of carrying out any works that the Authority is empowered to carry out; and temporarily close to traffic the road or any part of it, if it is necessary to do so for the carrying out of such works.

The water corporation must comply with the requirements of the *Road Management Act 2004*, before entering into and doing works on roads.

### 2.1.4 Section 149

Section 149 of the *Water Act 1989* applies to the removal of trees and combined with the *Road Management Act 2004* (Vic) provides the basis for managing works which impinge on roadside and municipal reserve trees. Specifically it provides in part that:

- (1) An Authority may, by notice in writing, require the owner of any property to remove any tree on that property if the Authority reasonably decides that the tree is obstructing or damaging the Authority's works or that it is likely to obstruct or damage them.
- (2) If the tree required to be removed is not on land over which
  - (a) an easement exists in favour of the Authority; or

(b) an easement exists for water supply, sewerage or drainage purposes - the Authority must, subject to sub-section (7), pay appropriate compensation to the owner of the property in accordance with Part 5 of the Land Acquisition and Compensation Act 1986;

(7) An Authority is not liable to pay compensation for the removal of a tree that is planted after the completion of the works of the Authority that are obstructed, damaged or at risk.

### 2.1.5 Section 155

Section 155 of the *Water Act 1989* provides that:

(1) An Authority must cause as little damage and inconvenience as possible in the performance of its functions.

(2) An Authority is liable, unless this Act specifically provides otherwise, to compensate any person who has:

(a) sustained any pecuniary loss; or

(b) incurred any expense

as a direct, natural and reasonable consequence of the performance of the Authority's functions.

## 2.2 ELECTRICITY CORPORATIONS

The powers and responsibilities of Powercor and other associated electricity companies including their contractors are set out in the *Electricity Industry Act 2000* (Vic), *Electricity Safety Act 1998* (Vic) and *Electricity Safety (Electric Line Clearance) Regulations 1999* (Vic).

The Electricity Industry Act 2000 (State) is the relevant Act to the requirements set out in this manual, with specific reference made to section 93.

### 2.2.1 Section 93

Section 93 of the *Electricity Industry Act 2000* confers a number of powers on an electricity corporations in relation to the carrying out of works on land. These powers include the power:

(a) to enter upon any lands and sink bores and make surveys and do any other acts or things necessary for sinking bores or making surveys;

(b) with any equipment or devices, to receive, store, transmit, or supply electricity, water, brown coal or products of brown coal over, or under, any land and to enter on any land upon either side of such equipment and fell or remove any tree or part of a tree or any obstruction which in the opinion of the electricity corporation it is necessary to fell or remove;

(c) subject to the Road Management Act 2004, to enter upon any public or private land or roads and construct any works or place on under or over any such land or road any structure or equipment and repair, alter or remove any such structure or equipment or any works under its control; and

(d) to do all other things necessary or convenient for constructing, maintaining, altering, or using any works or undertakings of, or under the control of, the electricity corporation.

Under section 93(2) of the *Electricity Industry Act 2000*, in exercising the powers set out in section 93(1) of the *Electricity Industry Act 2000*, an electricity corporation must:

“ . . . do as little damage as may be and, must, if required within 2 years from the exercise of the powers, make full compensation to the owner of and all parties interested in any land for any damage sustained by them in consequence of the exercise of the powers.”

The entitlement to compensation under section 93(2) is not affected by anything to the contrary in Road Management Act 2004 or any right conferred by, or any obligation or duty imposed under, the **Road Management Act 2004**.

An access code issued by the Commission under this section must not confer any right or power, or impose any obligation or duty, which is inconsistent with the Road Management Act 2004. An access code has no effect to the extent of any inconsistency under subsection 93(7).

## 2.3 GAS ORGANISATIONS

The powers and responsibilities of SPI Networks and other associated gas supply organisations including their contractors are defined in the *Gas Industry Act 2001* (Vic). The sections of relevance to the requirements set out in this manual are sections 148 and 149.

### 2.3.1 Section 148(1)

Section 148(1) of the *Gas Industry Act 2001* gives a gas distribution company powers in relation to entry onto land including:

:

- (a) after giving 7 days' notice in writing to the occupier, enter upon any lands and make surveys and do any other acts or things necessary for making surveys; and
- (b) with any pipes, equipment or other devices, receive, store or convey gas over, or under, any land; and
- (c) after giving 7 days' notice in writing to the occupier, enter on any land on either side of any pipes, equipment or other devices referred to in paragraph (b), and fell or remove any tree or part of a tree or any obstruction which in the opinion of the gas distribution company or gas transmission company it is necessary to fell or remove; and
- (d) after giving 7 days' notice in writing to the occupier, enter upon any public or private land or roads and construct any works or place on under or over any land any pipeline, work, structure or equipment and may repair, alter or remove any such pipeline, work, structure or equipment or any works under its control; and
- (e) do all other things necessary or convenience for constructing, maintaining, altering, or using any pipelines, works or undertakings of the gas distribution company or gas transmission company.

### **2.3.2 Section 148(4)**

In exercising any of the powers under section 148(1) of that Act, a gas distribution company or gas transmission company must:

- (a) not stay on the land any longer than is reasonably necessary; and
- (b) if the powers relate to the carrying out of works, must, on completing the works, remove from the land all materials brought onto the land for the purposes of those works other than anything that the owner or occupier of the land agrees may be left on the land; and
- (c) leave the land as nearly as possible in the same condition as it was in before the exercise of the powers; and
- (d) co-operate as much as possible with the owner and occupier of the land.

### **2.3.3 Section 148(5)**

Section 148(5) of the *Gas Industry Act 2001* provides that:

“In the exercise of the powers under sub-section (1) a gas distribution company or gas transmission company must do as little damage as possible and must, if required within 2 years from the exercise of the powers, make full compensation to the owner of and all

parties interested in any land for any damage sustained by them in consequence of the exercise of the powers.”

### 2.3.4 Section 149

Section 149 of the Gas Industry Act 2001 gives power to gas distribution companies to enter onto and open and break up roads. However, this power is subject to the Road Management Act 2004.

Section 149(1) in particular provides that the gas distribution company may:

- (a) open and break up the soil and pavement of any public or private road or bridge; and
- (b) temporarily stop traffic on a road or bridge.

### 2.3.5 Section 149(3)

Under section 149(3) of the *Gas Industry Act 2001*, if a gas distribution company or gas transmission company has opened or broken up a road or bridge, it must:

- (c) bear or pay all reasonable expenses of the repair of the road or bridge for 6 months after it is restored, so far as those expenses have been incurred by opening or breaking up the road or bridge.

## 2.4 TELECOMMUNICATIONS ORGANISATIONS

The powers and responsibilities of Telstra, Optus and other associated Telecommunications companies, including their contractors, are defined in the *Telecommunications Act 1997* (Cth), *Telecommunications (Low-Impact Facilities) Determination 1997* and the *Telecommunications Code of Practice 1997* (made binding by Clause 15(2) of Schedule 3 of the *Telecommunications Act*).

Clauses relevant to the requirements set out in this manual are:

- Clauses 5, 6(1), 9, 10, 19(1), 42(1) & (2) and 43 Schedule 3 of the Telecommunications Act 1997 (Cth):
- Clause 3.1(2) of the Telecommunications (Low-Impact Facilities) Determination 1997; and
- Clause 2.3, 2.4 and 2.5 Telecommunications Code of Practice 1997.

#### **2.4.1 Clause 5 of Schedule 3 – Telecommunications Act**

Under clause 5 of Schedule 3 to the Telecommunications Act 1997, for the purposes of determining whether any land is suitable for its purposes, a carrier may:

- (a) enter on, and inspect, the land; and
- (b) do anything on the land that is necessary or desirable for that purpose, including, for example:
  - (i) making surveys, taking levels, sinking bores, taking samples, digging pits and examining the soil; and
  - (ii) felling and lopping trees and clearing and removing other vegetation and undergrowth; and
  - (iii) closing, diverting or narrowing a road or bridge; and
  - (iv) installing a facility in, over or under a road or bridge; and
  - (v) altering the position of a water, sewerage or gas main or pipe; and
  - (vi) altering the position of an electricity cable or wire.

#### **2.4.2 Clause 6(1) of Schedule 3 – Telecommunications Act**

If clause 6(1) of Schedule 3 to the Telecommunications Act 1997 (see paragraph 36.1) authorises a carrier to carry out the installation of a facility, clause 6(2) of Schedule 3 to the Telecommunications Act 1997 permits the carrier, in connection with the carrying out of that activity, to:

- (a) enter on, and occupy, any land; and
- (b) on, over or under the land, do anything necessary or desirable for those purposes, including, for example:
  - (i) constructing, erecting and placing any plant, machinery, equipment and goods; and
  - (ii) felling and lopping trees and clearing and removing other vegetation and undergrowth; and
  - (iii) making cuttings and excavations; and
  - (iv) restoring the surface of the land and, for that purpose, removing and disposing of soil, vegetation and other material; and
  - (v) erecting temporary workshops, sheds and other buildings; and
  - (vi) levelling the surface of the land and making roads.

### **2.4.3 Clause 9 of Schedule 3 – Telecommunications Act**

Clause 9 of Schedule 3 to the Telecommunications Act 1997 provides that:

- (1) If a carrier engages in an activity under Division 2, 3 or 4 [which deal with carriers' powers with respect to inspection, installation, and maintenance of facilities] in relation to any land, the carrier must take all reasonable steps to ensure that the land is restored to a condition that is similar to its condition before the activity began.
- (2) The carrier must take all reasonable steps to ensure that the restoration begins within 10 business days after the completion of the first-mentioned activity.
- (3) The rule in subclause (2) does not apply if the carrier agrees with:
  - (a) the owner of the land; and
  - (b) if the land is occupied by a person other than the owner – the occupier; to commence restoration at a time after the end of that period of 10 business days.

### **2.4.4 Clause 10 of Schedule 3 – Telecommunications Act**

Clause 10 of Schedule 3 to the Telecommunications Act 1997 provides that:

A carrier must, in connection with carrying out an activity covered by Division 2, 3 or 4 [which deal with carriers' powers with respect to inspection, installation and maintenance of facilities], meet the requirements state in Clause 2.5 of the Telecommunications Code of Practice.

### **2.4.5 Clause 19(1) of Schedule 3 – Telecommunications Act**

Under clause 19(1) of Schedule 3 to the Telecommunications Act 1997, a carrier must give at least 10 business days' written notice to the authority responsible for the care and management of a road before:

- (a) closing, diverting or narrowing a road;
- (b) installing a facility on, over or under a road;
- (c) altering the position of a water, sewerage or gas main or pipe; or
- (d) altering the position of an electricity cable or wire.

### **2.4.6 Clause 42(1) & (2) of Schedule 3 – Telecommunications Act**

Clauses 42(1) and (2) of Schedule 3 to the Telecommunications Act 1997 provide that:

- (1) If a person suffers financial loss or damage because of anything done by a carrier under Division 2, 3 or 4 [which deal with carriers' powers with respect to inspection, installation, and maintenance of facilities] in relation to:
  - (a) any property owned by the person; or

(b) any property in which the person has an interest;

there is payable to the person by the carrier such reasonable amount of compensation:

(c) as is agreed between them; or

(d) failing agreement—as is determined by a court of competent jurisdiction.

(2) Compensation payable under subclause (1) includes, without limitation, compensation in relation to:

(a) damage of a temporary character as well as of a permanent character; and

(b) the taking of sand, soil, stone, gravel, timber, water and other things.

#### **2.4.7 Clause 43 of Schedule 3 – Telecommunications Act**

Clause 43 of Schedule 3 to the Telecommunications Act 1997 provides that:

If under a provision of Division 2, 3 or 4 [which deal with carriers' powers of inspection, installation and maintenance with respect to installations], a carrier is empowered to:

(a) enter on land; or

(b) inspect land; or

(c) occupy land; or

(d) do anything else on, over or under land;

the provision also empowers:

(e) an employee of the carrier; or

(f) a person acting for the carrier under a contract; or

(g) an employee of a person referred to in paragraph (f);

to do that thing.

#### **2.4.8 Clause 3.1(2) – Telecommunications (Low-Impact Facilities) Determination**

Under clause 3.1(2) of the Telecommunications (Low-Impact Facilities) Determination 1997, a facility cannot be a low-impact facility if it is located in an area of environmental significance. Under clause 2.5 of the Telecommunications (Low-Impact Facilities) Determination 1997, an area is an “area of environmental significance” if it is:

(a) an identified property for section 3A for the World Heritage Properties Conservation Act 1983 (Cth);

(b) designated as a reserve for nature conservation purposes by State, Territory or Commonwealth legislation;

- (c) protected from significant environmental disturbance by State, Territory or Commonwealth legislation;
- (d) listed on the Register of the National Estate; or
- (e) listed on a register relating to heritage significance under State, Territory or Commonwealth legislation.

#### **2.4.9 Clause 2.3 – Telecommunications Code of Practice**

Clause 2.3 of the Telecommunications Code of Practice 1997 provides that:

“In engaging in a land entry activity, a carrier must take all reasonable steps to ensure that the carrier causes as little detriment and inconvenience, and does as little damage, as is practicable.”

#### **2.4.10 Clause 2.4 – Telecommunications Code of Practice**

Clause 2.4 of the Telecommunications Code of Practice 1997 provides that:

- (1) If a carrier engages in a land entry activity in relation to any land, the carrier must take all reasonable steps to ensure that the land is restored to a condition similar to its condition before the activity began.
- (2) The carrier must take all reasonable steps to ensure that the restoration starts within 10 business days after the completion of the land entry activity.
- (3) Sub-section (2) does not apply if the carrier agrees with:
  - (a) the owner of the land; and
  - (b) if the land is occupied by someone other than the owner – the occupier; to start restoration at a later time.

#### **2.4.11 Clause 2.5 – Telecommunications Code of Practice**

Clause 2.5 of the Telecommunications Code of Practice 1997 provides that:

A carrier must, in connection with carrying out a land entry activity take all reasonable steps:

- (a) to act in accordance with good engineering practice;
- (b) to protect the safety of persons and property;
- (c) to ensure that that the activity interferes as little as practicable with:
  - (i) the operations of a public utility;
  - (ii) public roads and paths;

- (iii) the movement of traffic; and
- (iv) the use of land; and
- (d) to protect the environment.

### **3. GENERAL REQUIREMENTS**

#### **3.1 CONSENT FOR WORKS**

Where specifically applicable to a utility organisation and in all cases of works undertaken by sub-contractor or private contractors a “Consent For Works Within Road Reserves” permit needs to be obtained from Council prior to the commencement of any works.

The utility Acts referred to above, generally require that entry onto roads to conduct works are subject to the Road Management Act 2004. In any event, if they don't the Road Management Act applies to works on roads pursuant to section 63 of the *Road Management Act 2004*.

In relation to notification of intention to undertake works, plans showing proposed works and traffic management plans are required to be submitted to Council, allowing a relevant period to enable assessment and provision of conditions for undertaking the works to be prepared. The relevant period is specified to be 20 business days as stipulated under Clause 17(5) of Schedule 7 of the *Road Management Act 2004* (Vic).

#### **3.2 NOTIFICATION OF WORKS**

Utility companies and their contractors / sub contractors must notify Council's Reinstatement Officer when commencing works onsite. At the completion of works an inspection of the works must be undertaken with Council's Reinstatement Officer for the purpose of identifying variations to the standard reinstatement extents and/or inspecting reinstatements already undertaken.

#### **3.3 PUBLIC NOTIFICATION OF WORKS**

The utility company shall be required to letter box all properties affected by the works. This notice shall include the relevant after hours contact details for the contractor and those of the utility company. In addition, after hour contact details are to be displayed in a prominent location on site.

Should Council be required to attend the site outside normal business hours, then all costs for this response shall be debited to the relevant Service Authority.

#### **3.4 NOTIFICATION OF EMERGENCY WORKS**

Where a utility company is required to undertake emergency works under clause 63 of the *Road Management Act 2004* (Vic) then Clause 7(2) of Schedule 7 of the *Road Management Act 2004* (Vic) will apply and notification of the works being undertaken,

including plans of such works, is required within five (5) business days of the completion of works.

An emergency is defined under the *Emergency Management Act 1986* (Vic):

**emergency** means an emergency due to the actual or imminent occurrence of an event which in any way endangers or threatens to endanger the safety or health of any person in Victoria or which destroys or damages, or threatens to destroy or damage, any property in Victoria or endangers or threatens to endanger the environment or an element of the environment in Victoria including, without limiting the generality of the foregoing -

- (a) an earthquake, flood, wind-storm or other natural event; and
- (b) a fire; and
- (c) an explosion; and
- (d) a road accident or any other accident; and
- (h) a disruption to an essential service.

### **3.5 PUBLIC SAFETY**

From the date of commencement until full completion of the works, the utility company performing the road opening shall take all reasonable precautions for the safety of the general public and shall be liable for any acts of omission that result in injury or property damage.

The utility company is responsible for ensuring that their contractors have suitably secured the work site and stock piling sites associated with the works.

### **3.6 PROVISION FOR TRAFFIC**

The utility company performing the road opening shall be responsible for the safe usage of the site by traffic and pedestrians. An approved traffic management plan as attached to the "Consent For Works Within Road Reserves" Permit from Council (see Section 3.1) and signed "Memorandum of Consent" for alteration to speed limits from VicRoads are required to be held on-site for the duration of works and enacted prior to commencement of works in accordance with best practice. All necessary warning signs, lights, and barriers erected in accordance with the traffic management plan are to be maintained in accordance with the traffic management plan and in a clean and serviceable condition which meets the required reflectivity criteria.

Traffic Control is to be, at a minimum, to the requirement of 'AS 1742.3-2009 : Manual of uniform traffic control devices - Traffic control devices for works on roads' or 'Worksite Safety : Traffic Management Code of Practice, Victoria Government Gazette No. S276, 22 December 2004'.

### **3.7 HOURS OF WORK**

Unless otherwise specified, or except in an emergency, no work shall be carried out on the road reserve outside daylight hours or times specified for residential works in the Environment Protection (Residential Noise) Regulation 2008:

- Monday to Friday: before 7am and after 8pm.
- Weekends and Public Holidays: before 9am and after 8pm.

### **3.8 UTILITY COMPANY REPRESENTATIVES**

On commencement of major work, the utility company shall advise the Council on the names and telephone numbers (both work hours and after hours numbers) of the representative/s designated to respond to any emergency reported at that worksite.

### **3.9 SITE OFFICES**

Council approval is required for the establishment of temporary compounds used for storing materials, pipes, backfill, plant, site office etc. Notification of the need for a compound to be created is to be included in the application for consent to expedite approval times.

Where the establishment of a temporary compound is located in Council Park or Reserve, a leasing fee applies and formal arrangements need to be made with Council's Recreation Liaison Officer.

### **3.10 DAMAGE TO COUNCIL INFRASTRUCTURE**

The Code Of Practice for the Management Of Infrastructure In Road Reserves attached to the Road Management Act 2004 provides for Road Authorities, including Council to recover costs for damage to its infrastructure resultant from works undertaken by a Utility or failure of a Utilities asset.

Council advises that all planned works affecting the roadway (road pavement) should only commence once a pre-inspection has been undertaken with Council's Reinstatements Officer. Where reinstatements are undertaken by Council on behalf of the Utility no separation of claim for recoverable works will be made for repair of 'consequential' damage attributed to the utility or its asset. Extent of repairs and requested areas shall be itemised on the claim where requested.

#### **3.10.1 Clause 55 - Damage To Road And Other Infrastructure**

(1) The utility should conduct an inspection before commencing works in a road reserve, to identify and record the details of any damaged road and other infrastructure within the

limits of the proposed works. In accordance with clause 9 of Schedule 7 of the Act, if there is pre-existing damage to any road and other infrastructure, the utility should advise the road authority before works commence if it is aware of such damage, or as soon as the damage becomes evident to the utility. The utility is not required to fund repairs to pre-existing damage to road and other infrastructure.

(2) If a utility damages another infrastructure manager's infrastructure whilst working in a road reserve, it should advise the infrastructure manager of the damaged infrastructure as quickly as possible to enable the infrastructure manager to arrange for repairs to be carried out, with the utility causing the damage being responsible for all reasonable repair costs.

### **3.10.2 Clause 59 - Failure Of Utility Infrastructure In Road Reserves**

(1) In accordance with clause 6 of Schedule 7 of the Act, where the failure of utility infrastructure causes damage to road infrastructure, the utility should be responsible for returning that road infrastructure to the condition that existed prior to that failure, to the extent that this is established. The utility should also be responsible for reimbursement of reasonable road authority costs involved in assisting with such emergency repairs.

## **3.11 ENVIRONMENTAL AND CULTURAL HERITAGE PROTECTION ZONES**

It is the requirement of the Utility Company and any contractors to undertake all due diligence in identifying environmental and cultural heritage protection zones within the road reserve. Such zones are prevalent in the City of Greater Geelong boundaries and whilst predominantly in rural areas, urban sites exist.

Sites previously identified within the City have included, but are not limited to, the following items:

- River red gums
- Growling Grass Frog
- Remnant native grass
- Aboriginal artifacts

Where works are identified to encroach on an area protected by legislation, it is the responsibility of the Utility Company and its contractors to obtain the necessary permits and work approvals prior to commencing work on site. Notification of identified sites and a copy of the associated assessment reports must be provided to the City's Environment and Natural Resources department.

## 4. CONSTRUCTION REQUIREMENTS

### 4.1 LOCATING INFRASTRUCTURE IN THE ROAD RESERVE

All utility infrastructure within road reserves shall be clear of roadway and parallel or at right angles to the centreline of the roadway unless otherwise agreed with the relevant co-ordinating road authority.

#### 4.1.1 Aerial Infrastructure – Position and Height Clearance

Aerial services shall have a minimum height clearance of 5.5 m above the finished road surface level or the natural surface. The installation shall conform to the requirements of the Electricity Safety (Installations) Regulations 2009, Tables 223.1 and 223.2. Poles for aerial services shall have a minimum lateral clearance of 3 m from the edge of carriageway in urban areas, unless agreed otherwise, and 9 m in rural areas, except where frangible poles are used.

#### 4.1.2 Underground Infrastructure - Arterial Roads (Appendix B)

Unless otherwise agreed, utility infrastructure and associated conduits installed under roadways for freeways and arterial roads shall meet the requirements of the Road Management Act 2004 and Roads Corporation of Victoria Standard Section 706.

Damage to services and assets incurred as a result of failure to meet these requirements will be the responsibility of the utility company.

#### 4.1.3 Underground Infrastructure - Municipal Roads

For consistency between road authorities, the City of Greater Geelong has adopted the same standard requirements for the depth of service authority infrastructure installations as the Roads Corporation of Victoria, see above for details.

Where variation to the adopted standard is agreed, utility infrastructure and associated conduits installed under roadways for municipal roads shall be at depths to provide cover at finished level of no less than the following:

	Finished Road Surface Level (Absolute Minimum)	Invert Level Of Roadway Open Drains (Absolute Minimum)
Utility infrastructure and associated conduits <75mm	600mm	450mm
Utility infrastructure and associated conduits >75mm	800mm	450mm
Electrical conduit and cabling <1kV	800mm	500mm
Electrical conduit and cabling >1kV	1200mm	750mm

Damage to services and assets incurred as a result of failure to meet these requirements will be the responsibility of the utility company.

#### 4.1.4 Underground Infrastructure - Public Pathways and Roadsides

Underground telecommunications cable installed under public pathways or in roadsides shall be:

- a. enclosed in compliant conduit at a minimum depth of 450mm or as otherwise agreed with the relevant local authority; or
- b. covered by a white marking tape which includes lettering to identify the service and which complies with AS/NZS 2468.1 1995 and is installed a minimum of 100mm above the cable.

Underground electrical cable installed in a road reserve (pathway or roadside only) shall be in accordance with the minimum depths from the surface of the ground specified in AS/NZS 2053 – Conduits and fitting for electrical installations and the *Electricity Safety (Installations) Regulations 2009 (Vic)* as per Table 1.

**Table 1 - Depths for Electrical Conduit Installation**

Type of underground line Nominal voltage ("U")	Directly buried	Directly buried and covered with a mechanical cover	Buried enclosed in a conduit or pipe
U < 1500V direct current	750 mm	600 mm	500 mm
Alternating current U ≤ 1kV	750 mm	600 mm	500 mm
1kV a.c. or 1500V d.c. < U ≤ 22kV	900 mm	750 mm	750 mm
22kV < U ≤ 66kV	1000 mm	750 mm	750 mm
66kV < U ≤ 220kV	1000 mm	1000 mm	1000 mm

## 4.2 REMOVAL OF SPOIL

All excavated material not required or approved for backfill shall be removed from the site, to the Municipal landfill or a site approved under the *Planning and Environment Act 1987*, and the *Environment Protection Act 1970*.

The whole site shall be kept in a clean and orderly condition and rubbish removed daily. All excavated spoil shall be kept clear of drainage channels/paths.

The utility company shall be responsible for keeping municipal roads which access the site, free from rubbish, dirt, and mud transported to or from their site, either in or on vehicles associated with the site.

Areas affected by the work shall be restored to a condition similar to that which existed prior to commencement of the work, or to a condition approved by Council's Manager - Engineering Infrastructure.

### 4.3 STOCKPILING MATERIAL

All materials (minimum amounts only) which are required for the works shall be stored on the road reserve if the utility company finds it necessary to do so, and signed according to AS1742.3 or VicRoads "Signing Code of Practice". Excavated material is to be stockpiled for no more than 24 hours.

The utility company shall not obstruct the channels in any street, but shall deviate them where necessary and use all proper measures to provide for the free passage of water along the street channels by installation of pipes or other means.

No material shall be placed to interfere with the travelled path of vehicles.

Granular materials shall only be stockpiled on paved or granular surfaces. Natural surfaces must be avoided.

Any areas used for stockpiling must be restored, following its use, within 24 hours of works completion to a condition similar to that prior to commencement of works.

### 4.4 CONDUITS

#### 4.4.1 Colour of Conduit – Hazardous Service

**In most countries including Australia, standard colours are used to identify hazardous services provided in conduits. The Australian Standard AS-1345: 1995 Identification of the contents of pipes conduits and ducts (based on international standards) specifies the relevant colours for hazardous services.**

**Table 2 - Conduit Colours for Hazardous Services**

<b>Colour</b>	<b>Associated hazardous service</b>
orange	electrical power
yellow or yellow-ochre	fuel, process, toxic or medical gases
silver grey	steam
brown	flammable and combustible liquids
violet	acids and alkalis
light blue	compressed air

Conduits that contain telecommunications cables shall not be of a colour specified in Table 2

#### **4.4.2 Colour of Conduit – Telecommunications Service**

Non-metallic conduit for **all outdoor use** shall be coloured white or contain an indelible or durable continuous white stripe which is incorporated as part of the manufacturing process. Conduit must also be legibly and durably marked 'COMMUNICATIONS'.

Hazardous conduit is not to be painted white and then used by cabling providers for installing outdoor customer cabling.

### **4.5 INSTALLING INFRASTRUCTURE UNDER ROADWAYS**

#### **4.5.1 Boring**

Unless otherwise specified or approved by the coordinating road authority, all utility infrastructure (including conduits) under road carriageways shall be installed by boring.

Unless otherwise specified or approved by the coordinating road authority, boring by water jetting will not be permitted.

Unless otherwise specified or approved by the coordinating road authority, the annulus between the bore and the pipe or carrier-conduit shall be filled by pressure grouting.

Unless otherwise approved by the coordinating road authority, openings cut to permit boring shall be outside of the roadway.

Any damage to Council's assets by the use of soil displacement hammers shall be made good by the utility company to the satisfaction of Council's Manager - Engineering Infrastructure

#### **4.5.2 Excavation**

Where the open trench method of crossing under a roadway is accepted, the line of the trench shall be straight, at right angles to the roadway and form the shortest link between terminals wherever practical. The width of trench shall not be greater than that necessary to carry out the work, but wide enough to carry compaction equipment.

The edges of all trenches located within a paved roadway, paved pathway or vehicle crossover shall be saw-cut.

Any infrastructure located within the road reserve that is disturbed as a result of the work shall be reported immediately to the Council's Manager - Engineering Infrastructure and shall be reinstated promptly in consultation with the relevant infrastructure manager. Any stormwater drainage or municipal infrastructure damaged as a result of the work shall be reported immediately to the Council's Manager - Engineering Infrastructure and shall be replaced promptly in consultation with the relevant infrastructure manager.

Trenching required to be open shall be kept to an absolute minimum at all times. All trenches required to be left open must be left in a safe condition and covered by a steel / aluminium plate or securely fenced.

## 4.6 EXCAVATION NEAR TREES

### 4.6.1 Background

Urban infrastructure requirements take a heavy toll on existing trees. Both overhead and underground services and associated works can impact significantly on the trees health and safety. All street trees grow in a non-natural environment with conflicting demands for the same space.

Trees require strict systems of protection to ensure works in their vicinity are controlled. Trees are a living asset and take many years to mature and as such once damaged cannot realistically be repaired or replaced.

Where the utility company require work excavations near or close to a Council Park or Street Tree, the utility company is accountable if damage is caused to any part of a tree either above or below ground.

### 4.6.2 Tree Roots

A tree's root system generally grows in the top 600mm of soil and can extend radially (outwards) to a distance much greater than the tree's height (see Figure 1). However this can vary depending on species with the deepest roots being close to the trunk and becoming shallower as the root develops out from the tree.

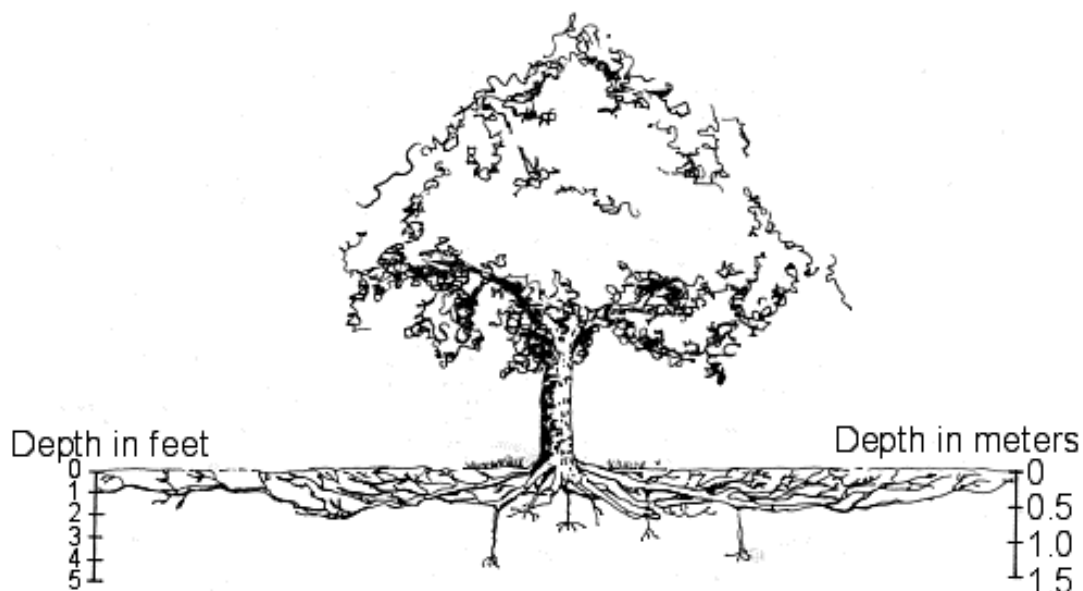

**Figure 1 - Tree Root Depths**

Tree roots do not stop at the 'Drip Line' of the tree, but extend well beyond the canopy line. Usually the most important feeder roots of the tree extend outwards from the canopy drip line. Ideally the whole of this area should be protected and remain undisturbed during construction work. If works are necessary within the tree's potential rooting area, then planning for proposed works should stipulate construction methods that avoid excavation

in the identified minimum protection zone from the base of the tree's trunk. This protection zone generally equals the full extent of the branch spread or be equivalent to half the tree's height, whichever is greater (See Figure 2 and Figure 3).

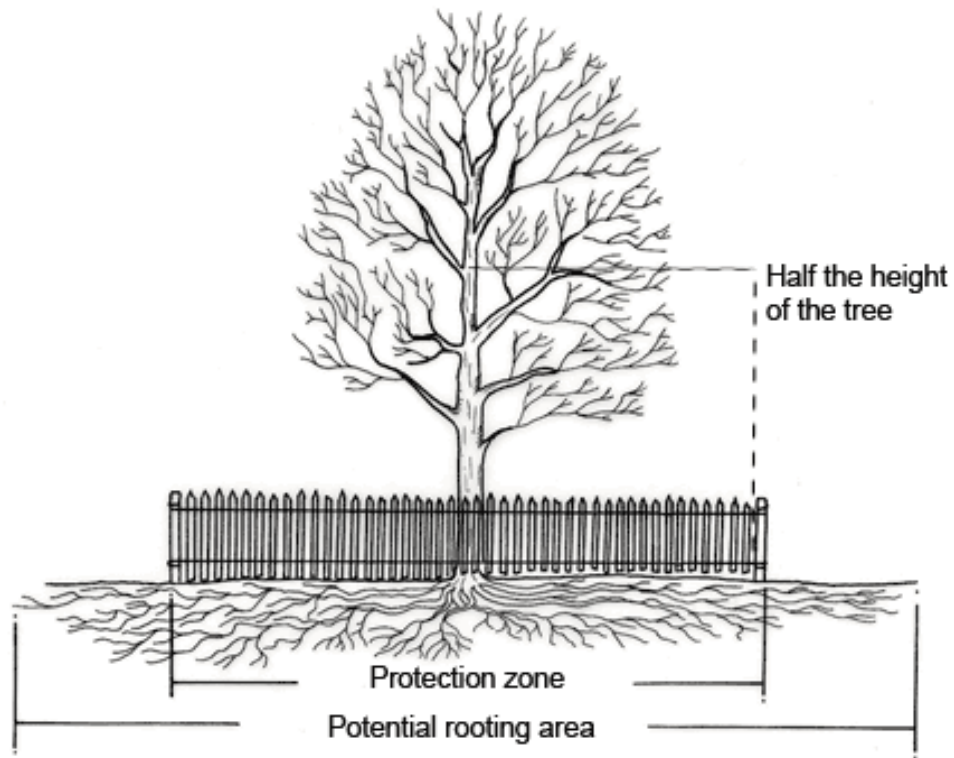

**Figure 2 Minimum Protection Zone compared to Potential Rooting Area**

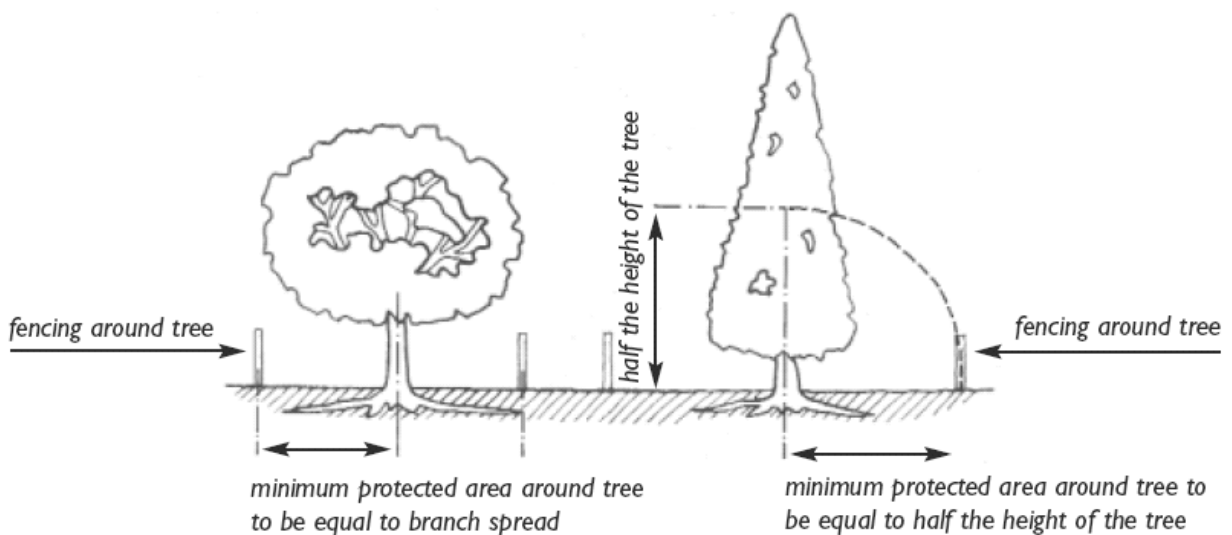

**Protect the tree to whichever is the greater of these two methods of measurement. The zone within the fencing as shown above, is known as the Minimum Protected Area.**

**Figure 3 Minimum Protected Area**

### 4.6.3 Works Relating to Utility Companies

Council's Manager - Engineering Infrastructure requires copies of all plans of proposed works by the utility company for comment, investigation and approval prior to the commencement of proposed work, to allow for site inspections and agreement of methods employed to complete the proposed works in order to protect the tree or trees from above or below ground damage.

Prior to utility company arriving on site specific conditions such as pruning or underground boring or limiting the extent of excavation should be agreed to and stated on plans. In some cases, the removal of trees would be agreed to.

Cost of tree removals and replanting to be covered by the utility company unless otherwise agreed to by Council.

Boring is the preferred method of by passing the tree.

In most cases, due to the uncertainty in determining the extent of tree root systems, on site decisions need to be determined as works progress. The Council Arboricultural Officer can arrange to remain on site whilst excavation or boring work takes place to determine when it is necessary to hand excavate to prevent tree root damage.

No utility company shall excavate in the vicinity near any street tree without the approval of Council and the relevant approval being issued. Minimum clearances to be adhered to are calculated by a scale based upon trunk diameter at 500mm above ground level. The figures are a guide only and can vary depending on tree species, locality, and conditions.

It is normal practice to bore for service installation inside the drip line of the tree.

<b>Trunk Diameter</b>	<b>Excavation Distance from Tree</b>
15cm	1.5m
30cm	2.0m
45cm	3.0m
60cm	4.0m

**For larger trees above 60cm trunk diameter the excavation distance from the tree trunk will be negotiated on inspection of site and marked on plan as condition of approval, i.e. - drip line to drip line.**

All roots above 4cm in diameter are to be retained and must be hand dug around to avoid root damage.

**Regardless of specific requirements stated on plans and or contract documents, or the absence of them, the “Root Plate” areas and larger areas of “Feeder Roots” must not be damaged during excavation works or boring works associated with the new installation of repair of any underground service which should adversely affect the health and vigour of the Council’s Tree Asset.**

Damage caused to any Council assets including trees (in park areas or streets) can result in claims for compensation costs against the utility company concerned with the project.

No utility company shall remove, lop, or prune trees or damage root systems by excavation without having first sought approval as to the best course of action from the Council’s Manager - Engineering Infrastructure.

In such cases Council will seek restitution by one of the following methods.

- (a) Compensation of the full amenity value of the tree should it be proven that the tree has been negligently devalued using the valuation policy adopted by Council.
- (b) Any tree shall be repaired by Council staff at the utility company expense.
- (c) That a suitable replacement tree species as determined by the Councils Arboricultural Officer to be paid for by the utility company including planting and follow up maintenance for a period of twelve months.

#### **4.6.4 Other Works Within Road Reserves Affecting Trees, Shrubs, and Indigenous Vegetation**

For all works within road reserves, the utility company must advise council of their intention for main laying. Where any indigenous vegetation is located in association with proposed works appropriate liaison and approvals are required from Council’s Environmental Officer to protect possibly rare indigenous vegetation.

Note: some native indigenous vegetation is protected by legislation which carries substantial penalties.

All work near trees, shrubs, and indigenous vegetation within road reserves or on public reserves shall comply with the above conditions. In some cases further details regarding proposed works and Council assets above and below ground will be required via the Council’s Manager - Engineering Infrastructure.

#### **4.6.5 Branches Obstructing Works**

Councils pruning program does not always allow for enough clearance to allow construction and excavation equipment underneath the tree canopy. Council does not permit any tree branch to be broken off either by hand or machinery. This must be arranged through Council’s Manager - Engineering Infrastructure.

**Neither Council nor its ratepayers will tolerate damage being unduly caused by utility company to the above or below ground component of the Councils Tree Asset.**

Council is responsible for the maintenance of trees within its road and reserves and is willing to comply with reasonable requests for maintenance to trees. This may be at cost to the Council or the utility company depending on circumstances.

#### **4.6.6 Removal of Trees by Utility Company**

In circumstances where trees may be removed by utility companies when underground services are being repaired or renewed, special provisions will apply to ensure all replacement costs are provided for by the utility company concerned. Council's Manager - Engineering Infrastructure, is to be advised by the utility company of this work. A Council officer will then inspect the work site to approve the removal of the tree and determine the replacement species.

## 5. REINSTATEMENT OF WORK AREA

### 5.1 MATERIALS

Unless otherwise specified, materials used for bedding and backfilling shall be uniform in composition and free from perishable matter and shall comply with the requirements specified in Table 3.

**Table 3 - Material Properties**

Material	Sieve Size - AS (mm)					Plasticity Index	
	Percentage Passing (by mass)						
	75.0	37.5	19.0	2.36	0.075	min	max
Bedding	-	-	100	-	10-40	2	10
Selected backfill	-	100	-	-	10-40	5	20
Common backfill	100	-	-	40-100	-	-	-

#### 5.1.1 Class 2 and Class 3 FCR

Where Class 2 and Class 3 Fine Crushed Rock is specified for use in roadway reinstatements, the material shall be quarry sourced virgin rock. Crushed concrete shall not be used as a Class 2 or Class 3 material in roadways, but may be used for reinstatements in concrete pathways.

### 5.2 BEDDING

Where bedding is required, bedding shall be placed below, around and above the pipe or carrier-conduit for the full length of the trench. Not less than 25mm depth of bedding shall be placed below and not more than 150 mm depth of bedding shall be placed above the pipe or carrier-conduit. Bedding shall not be placed in layers exceeding 150 mm loose thickness and shall be compacted as specified.

### 5.3 BACKFILLING

Unless otherwise specified, selected and common backfill shall be placed and compacted as follows under, around, and above the conduit after the sections are bedded:

### **5.3.1 Conduits under Unpaved Areas**

In unpaved areas the opening shall be backfilled with common backfill placed and compacted as specified in layers not exceeding 200 mm loose thickness.

The top 100mm of backfill shall be in a good quality loam or top soil.

### **5.3.2 Conduits under Existing Paved Areas including Shoulders and Verges**

Unless otherwise specified (Section 6 - Council's standards), in existing paved areas, including gravel shoulders and gravel roads, the opening shall be backfilled to the existing subgrade level with selected backfill material placed and compacted in layers not exceeding 150 mm loose thickness and the pavement material placed and compacted in layers not exceeding 100 mm loose thickness using materials in accordance with Clause 5.1

## **5.4 COMPACTION STANDARDS**

### **5.4.1 Bedding and backfill (except pavement)**

Unless otherwise specified, bedding and backfill shall have during compaction a uniform moisture content within the range 85% to 115% of the optimum moisture content as determined in the Standard compactive effort. For backfill of nominal size greater than 40 mm the fraction of material passing the 37.5 mm sieve shall have during compaction a uniform moisture content within the range 85% to 115% of the optimum moisture content as determined for that fraction in the Standard compactive effort.

Bedding and backfill shall be compacted to refusal using hand held mechanical equipment.

### **5.4.2 Pavement**

Unless otherwise specified, pavement material shall have during compaction a uniform moisture content within the range 85% to 115% of the optimum moisture content as determined in the Modified compactive effort.

## **5.5 COMPACTION EQUIPMENT**

### **5.5.1 Vibrating Plate Compactors**

Vibrating Plate Compactors, also known as "Whacka Plates" provide a consistent compaction over a finished surface. Whilst the weight of the compactor plate required to adequately compact material within deeper trenches may preclude their use on Occupational Health and Safety Grounds, the final compaction prior to and after sealing are best serviced by the larger plates available on a vibrating plate compactor. Units of a minimum 88kg weight are required to provide proper depth compaction in road

carriageways. Smaller units of 55kg may be suitable for use in footpath and driveway reinstatements subject to compaction in no more than 100mm layers.

### 5.5.2 Tamping Rammers

Tamping rammers, also known as trench rammers, jumping jacks or kangaroo rams are a recognised method of compacting loose backfill material within trenches often dug for service installation. Due to the motor head of a tamper rammer being larger than the plate width, tamper rammers are only appropriate for use when the trench depth to top of service is no greater than the distance between the base of motor (neck) and compacting plate (designated as X in Figure 4) + 150mm. Jumping of the ram is to be avoided.

To enable proper compaction to be achieved across the full trench width, where a trench rammer is proposed to be used in the backfill operation, the trench width shall be:

Trench Type	Maximum trench width	Example: (trench width using tamping rammer with 280mm wide plate)
Single Pass (narrow trench)	Width of tamping plate + 10mm	280mm + 10mm = 290mm
Multi-Pass	(Width of tamping plate – 20mm) x No of Passes to compact a single layer	(280mm – 20mm) x 3 = (260mm) x 3 = 780mm

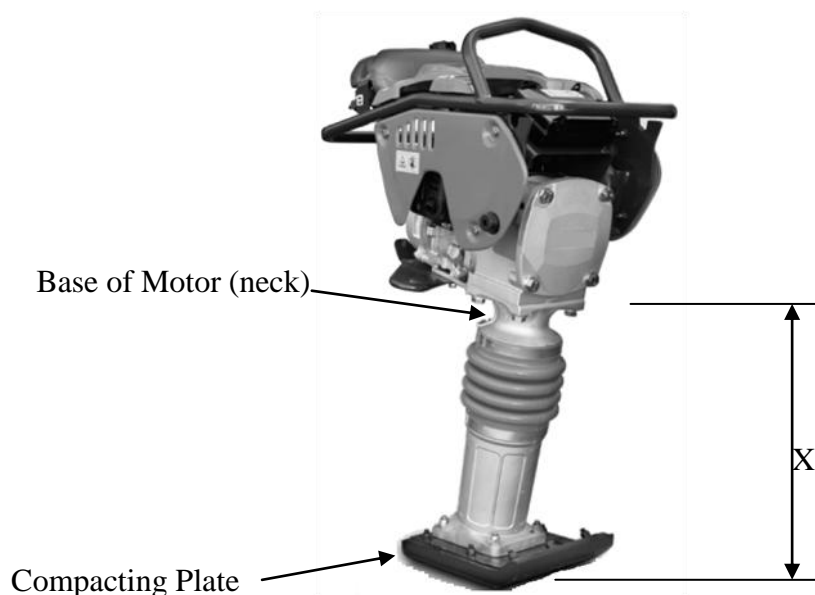

Figure 4- Tamping Rammer

## **5.6 TESTING**

For any trench or shaft in a sealed pavement Council's Manager - Engineering Infrastructure may nominate that compaction testing be undertaken by a NATA registered tester. The utility company shall be responsible for arranging the testing and supplying results to Council's Manager - Engineering Infrastructure prior to implementing the final seal.

If the works fail to pass the required compaction test then the utility company will be required to remove the non-compliant sections and reinstate material to specification. If the defect is not addressed within the allocated timeframe, then Section 5.16 - Failure to comply shall apply.

Testing shall be undertaken in accordance with the following:

### **5.6.1 Bedding and backfill (except pavement)**

Backfilling beneath areas to be paved shall be assessed for compaction in lots as defined in VicRoads Standard Section 173. The number of tests per lot shall be three. Backfill, the whole of which passes the 37.5 mm AS sieve, shall be compacted to a mean value of density ratio of not less than 97%. The calculation of density ratio shall be based on Standard compactive effort. A lot shall consist of a single layer of work. A minimum of 20% of all lots constructed shall be tested.

### **5.6.2 Pavement**

Pavement material shall be assessed for compaction in lots as defined in VicRoads Standard Section 173. The number of tests per lot shall be three. All pavement layers shall be compacted to a mean value of density ratio not less than the 98%. All pavement layers shall be tested.

## **5.7 REINSTATEMENT QUALITY ASSURANCE**

All openings once reinstated shall not be allowed to settle more than 30 mm below that of the surrounding existing conditions before a notice is issued to rectify the reinstatement. This cost shall be borne by the utility company responsible for the original opening.

All road crossings on declared roads (list attached) shall be capped with compacted asphalt or compacted premix (temporary) within 24 hours. All crossings on sealed Municipal roads shall be capped to the same standard and requirements as arterial roads.

## **5.8 MAINTENANCE**

The backfilled surface shall be maintained in a trafficable condition after the completion of backfilling. Additional pavement material shall be placed in the trench and compacted as specified where in paved areas settlement or loss of material from the surface exceeds 20 mm measured from a straight edge laid across the top of the trench

All reinstatement of Council's assets will be subject to a maintenance period the greater of 12 months as per the *Road Management Act 2004 (Vic) - Code of Practice*. If at any time during this period the reinstatement works fail or move outside the tolerance indicated in the Council Standards, a notice to rectify will be issued to the utility company responsible for the original opening. If the situation noted is not addressed within the allocated timeframe, then Section 5.16 - Failure to comply shall apply.

## **5.9 FINISHED SURFACE REINSTATEMENT**

The utility company must notify the Council's Manager - Engineering Infrastructure for the reinstatement of the road / footpath / naturestrip surface disturbed by its operations within 48 hours of completion of works.

Council shall be notified prior to any works being undertaken in relation to all road crossings on declared arterial roads (list attached) for reinstatement purposes.

## **5.10 TIMING OF REINSTATEMENTS**

Temporary reinstatements (See Section 5.11) are to be used where open trenches are no longer required and until permanent reinstatement is undertaken.

Permanent reinstatements directly managed by a utility company are to be undertaken within 10 business days of the completion of the works unless a variation to this time is agreed by Council's Manager - Engineering Infrastructure.

Requests to undertake permanent reinstatement which are lodged with Council and abut an active building site will, unless agreed otherwise, not be undertaken prior to completion of the building activity. The utility company will remain responsible for public safety and the condition of the reinstatement area until completion of the building activity permits the permanent reinstatement to be undertaken.

Where a utility company fails to meet the above requirements then Section 5.16 - Failure to comply shall apply.

## **5.11 TEMPORARY REINSTATEMENTS**

At the completion of required works within any open trench, a temporary reinstatement is to be undertaken to make the area safe for pedestrian and vehicle traffic. Temporary reinstatements are to be in accordance with the layer thickness and compaction requirements for permanent reinstatements, but shall use cold mix asphalt for the final 100mm as the wearing course until such time a permanent hot mix reinstatement is undertaken.

Where a temporary reinstatement is not undertaken in accordance with the layer thickness and compaction requirements then permanent reinstatements shall require removal of all material from the trench and reinstatement with material and layers complying with the requirements of this manual.

The utility company undertaking the works shall be responsible for ensuring the condition of the temporary reinstatement remains at an appropriate standard for public safety and shall undertake immediate rectification when a defect is identified and/or reported.

## **5.12 EXTENT OF REINSTATEMENTS**

The final extent of reinstatement required is to be determined after inspection by Council's Reinstatement Officer. In accordance with Section 3.10 DAMAGE TO COUNCIL INFRASTRUCTURE, a pre-inspection should be undertaken to determine expected reinstatement extents. Final extents will then be detailed during the post construction inspection specified in Section 3.2 notification of works.

### **5.12.1 Roads**

#### **5.12.1.1 Sealed**

Where trenching/boring or other construction works result in damage to the road surface, reinstatement must extend from the edge of the seal past the end of the damaged area to the nearest longitudinal joint line or centreline of the road. If the reinstatement required crosses the centreline then the reinstatement shall be the full width of the road. All reinstatements are to be a minimum 750 millimetres length, longitudinally along the road (Figure 5) or where the distance between multiple reinstatements required is less than five (5) metres then the full length of road covering all reinstatements. Requirements for multiple reinstatements on a road greater than five (5) metres apart shall be assessed on a case by case basis.

In addition to the above requirements, where a road has been resurfaced or constructed in the last 10 years, subsequent road reinstatement must extend for half the width of the road, from edge to centreline, and not just be confined to the trench. Should the trench cross the road centreline, then the full width of the road will need to be resurfaced

The only variation to the previously specified requirements shall be where the trench extends less than 450mm from the edge of the kerb tray, then the reinstatement shall be a minimum 600mm wide by 1000mm length and shall be compacted using approved compaction equipment. Damage to the kerb and channel from working within the angle of repose for the kerb shall be made good to the satisfaction of the responsible authority.

The finished wearing course must be asphalt and edged with crack sealant.

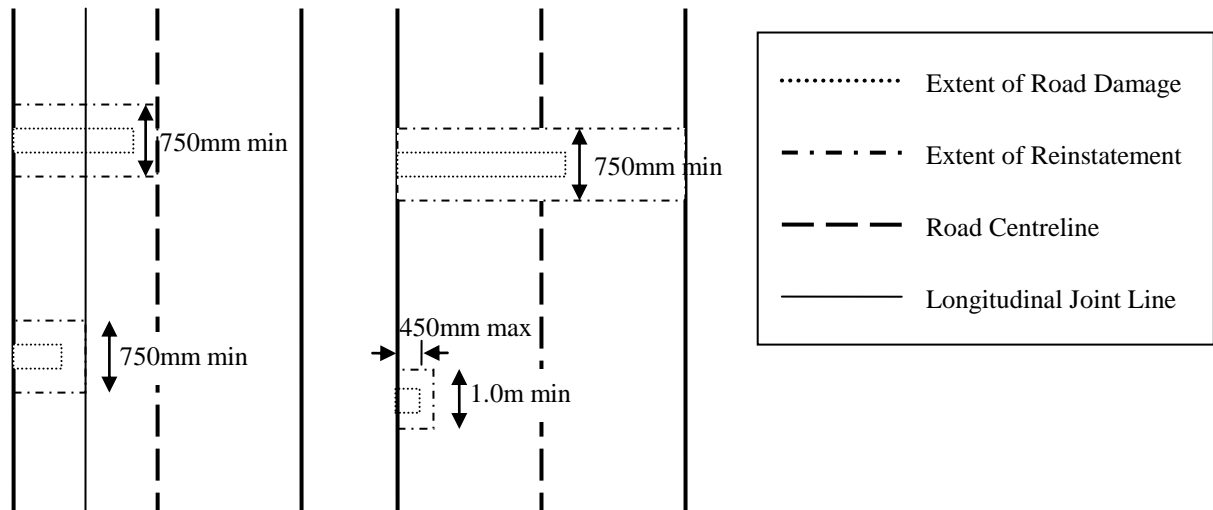

**Figure 5- Reinstatement Extents Sealed Road**

#### 5.12.1.2 *Unsealed*

Where trenching or boring works result in damage to the road surface, reinstatement must extend for the full width of the road and a minimum one (1) metre length, longitudinally along the road.

### 5.12.2 Footpaths and Driveways

#### 5.12.2.1 *Gravel*

All trenches are required to be reinstated for the full width of footpaths and half width of driveways with minimum length of 500mm. A smooth steel drum roller or plate compactor with minimum specification of 500mm plate width and 89kg weight must be used to compact the material.

#### 5.12.2.2 *Asphalt*

All trenches are required to be reinstated for the full width of footpaths and half width of driveways with minimum length of 600mm. Backfill material shall be compacted using approved compaction equipment.

#### 5.12.2.3 *Concrete*

All bays of concrete damaged as a result of works are to be replaced in full. No part bay replacements will be accepted.

### 5.12.3 Kerb and Channel

All bays of concrete damaged as a result of works are to be replaced in full. No part bay replacements will be accepted. All bluestone blocks removed are to be replaced to match existing construction extents, permanent removal of bluestone blocks is not permitted without prior approval from Council's Manager – Engineering Infrastructure.

### **5.13 PRE-CUTTING OF WORKS**

All concrete shall be cut prior to excavation. Joints shall be double cut to limit damage to adjoining bays. No bays shall be cut for part removal only. The full bay must be removed after cutting at the joints. Over-cuts into adjoining bays will require the over-cut bay to be replaced.

All bitumen surfaces shall be cut prior to the works commencing unless otherwise agreed by Council's Manager - Engineering Infrastructure. Double cuts should be used where practical to restrict damage to surrounding infrastructure.

### **5.14 STREET FURNITURE**

All street furniture removed (i.e. signs, bins, benches etc.) shall be reinstated by the utility company as soon as practicable after the trench has been backfilled.

All damaged furniture shall be replaced at the cost of the utility company .

Where the item concerned is a major traffic control item, (i.e. speed restriction signs, stop signs etc.) the utility company shall notify the council prior to removal and arrange for temporary signs to be installed until the existing signs are reinstated. These costs shall be borne by the utility company

The utility company shall be responsible for all street furniture while it is removed from its original site.

### **5.15 ROAD OPENING LIABILITY**

#### **5.15.1 Council Reinstating**

The utility company shall be liable for all openings within the road reserve for the lesser of 4 (four) weeks from the date that Council is notified that the road opening is ready for reinstatement or the reinstatement being completed.

#### **5.15.2 Private Contractor Reinstating**

The utility company shall be liable for all openings within the road reserve for the period until reinstatement is completed to an approved standard. Once reinstatement is complete a defects liability period shall commence and extend for the length of time specified allowable under the Act, being twelve (12) months.

## 5.16 FAILURE TO COMPLY

Where the utility company fails to undertake reinstatement of works in accordance with the requirements of this manual or produces a sub-standard reinstatement for inspection, clause 19 of Schedule 7 of the *Road Management Act 2004* (Vic) shall apply.

### **Clause 19 Power to rectify works on a road**

(1) If a coordinating road authority considers that any works have not been conducted in accordance with this Act, the coordinating road authority may give a notice to the road authority, infrastructure manager, or works manager that authorised or conducted the works requiring rectification works to be conducted within a reasonable period specified in the notice.

(2) If a road authority, infrastructure manager, or works manager fails to comply with a notice given under subclause (1), the coordinating road authority may conduct the rectification works or engage a person to conduct the rectification works on behalf of the coordinating road authority.

(3) A coordinating road authority may recover costs reasonably incurred in conducting rectification works from the road authority, infrastructure manager, or works manager that failed to comply with the notice given under subclause (1).

For the purposes of calculating reasonably incurred costs, the value shall be the construction cost incurred, plus a management and supervisory cost, being the greater of 10% of the construction cost incurred or 10 Penalty Units.

## 5.17 PERMITS REQUIRED UNDER LOCAL LAW

Under Council's Local Law Division 6 "Streets and Roads" No. 3 Section L7.24:

A permit is required.

1. No person may on a road under the control of the Council:
  - (a) Occupy or fence off part of a road;
  - (b) Erect a hoarding or overhead protective awning;
  - (c) Use a mobile crane or travel tower for any building work;
  - (d) Make a hole or excavation; or
  - (e) Reinstatement a hole or excavation - without first obtaining a permit.

Penalty: Five penalty units.

Failure to obtain a permit will result in a notice to comply being served on the responsible person and the appropriate penalty.

Failure to comply with the above notice will result in further action being taken by the Council.

## **5.18 EXEMPTION FROM PERMITS REQUIRED UNDER LOCAL LAW**

Under Council's Local Law Division 6 "Streets and Roads" No. 3 Section L7.29 Works of Service Authorities.

The provisions of Local Law 7.24 as above, do not apply to the works of any service authority.

*Note: Contractors not directly employed or contracted by service authorities must comply with Section L7.24.*

## **5.19 SPECIAL CIRCUMSTANCES**

Any situations that arise that have not been covered herein must be discussed with Council's Manager - Engineering Infrastructure.

## 6. COUNCIL'S STANDARDS

### 6.1 ROADSIDES

#### 6.1.1 Definition

The roadsides, commonly known as naturestrips, consist of all unpaved areas including batters between the property line and back of kerb or the edge of the roadway and between kerbs on medians and traffic islands.

##### 6.1.1.1 Standard

Roadsides as defined above shall be backfilled to 100mm below finished surface and brought up to finished levels with good quality loam or top soil (See Figure 6).

No clay lumps, foreign or other material unsuitable for the planting of lawns shall be present in any form whatsoever in the top layer.

After placing the topsoil, the naturestrip area shall be raked to a fine tilth and sown down with approved seed mix and rolled down to existing surrounding level and grade.

Particular attention should be paid to the level of the reinstated roadside to ensure that no ponding of water on footpaths occurs or mounding creates a tripping hazard.

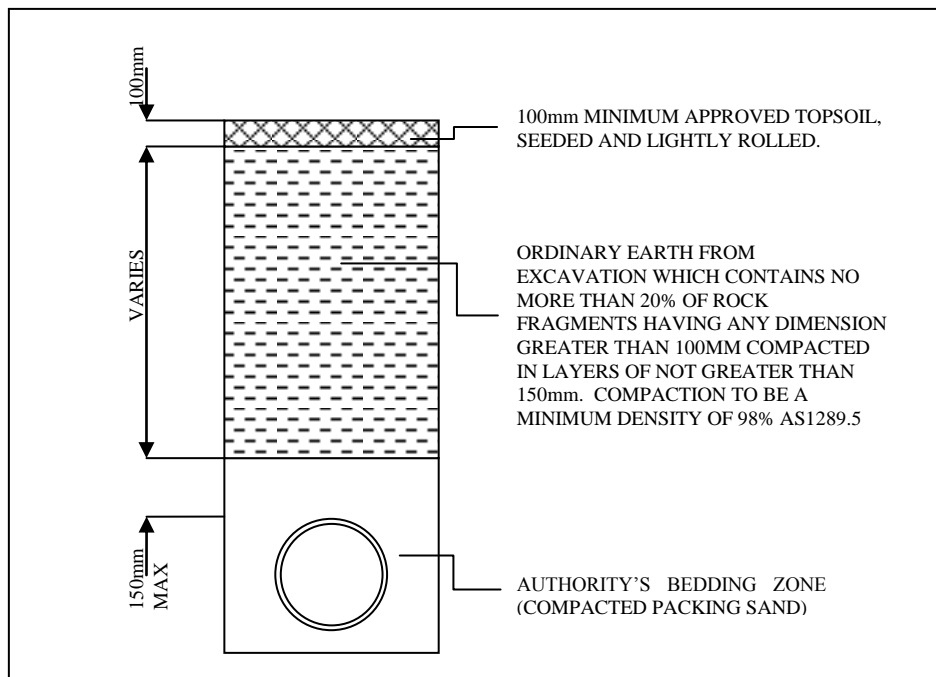

**Figure 6 Reinstatement of Trench in Naturestrip**

### 6.1.1.2 Tolerance

The finished surface shall not deviate at any point more than 20mm from the existing surface.

## 6.2 PATHWAYS

### 6.2.1 Gravel

#### 6.2.1.1 Standard

The trench up to within 150mm of the finished surface level (see Figure 7) shall be backfilled with ordinary earth removed from the excavation, but which shall contain not more than 20% of rock fragments having any dimension greater than 100mm.

This material shall be compacted by mechanical means in no more than 150mm layers.

The final 150mm to the surface level shall be compacted 20mm Class 2 Fine Crushed Rock or where the path is constructed of an alternate well graded crushed rock material, 150mm of that material compacted. It shall be compacted by mechanical means with optimum moisture to enable a minimum density of 95% Australian Standards 1289 .5. It shall be finished to existing level and grade.

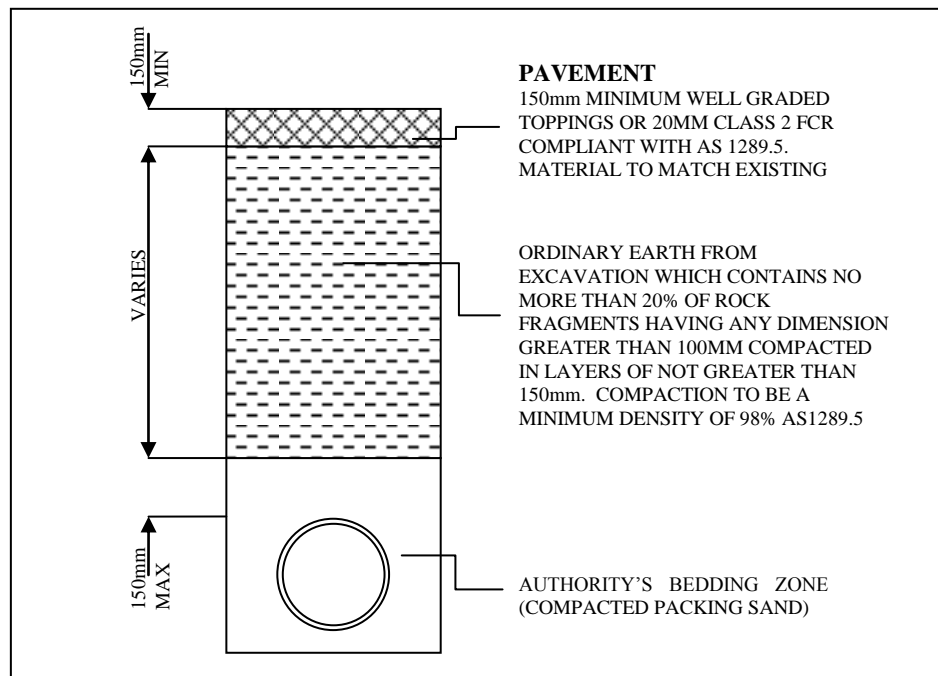

**Figure 7 Reinstatement of Trench through Gravel Footpath**

#### 6.2.1.2 Tolerances

The finished surface shall be true to level and grade of existing surrounding surfaces and not deviate at any point more than 20mm from the bottom of a 3 metre straight edge.

## 6.2.2 Asphalt

### 6.2.2.1 Standard

All trenches shall have excavated material removed from site and backfilled with 20mm Class 2 or Class 3 Fine Crushed Rock in accordance with Figure 8. The material shall be compacted by mechanical means in no more than 150mm layers.

It shall be compacted by mechanical means with optimum moisture to enable a minimum compaction of 95% Australian Standards 1289.5. It shall be finished to existing level and grade.

The existing footpath shall be saw-cut at not less than 150mm from each end of the finished excavated width of the trench.

The full width of the asphalt surface of the footpath shall be removed and replaced for the total length between saw cuts above.

All openings prior to being reinstated shall be trimmed to provide a minimum depth of 25mm for asphalt.

All asphalt placed shall be compacted by either steel wheeled roller or vibrating plate. The surface shall be smooth and durable for pedestrian use.

All edges shall be treated with emulsion prior to the placement of asphalt.

Asphalt supplied shall be nominal size 7mm type N. Colour to match that of existing footpath.

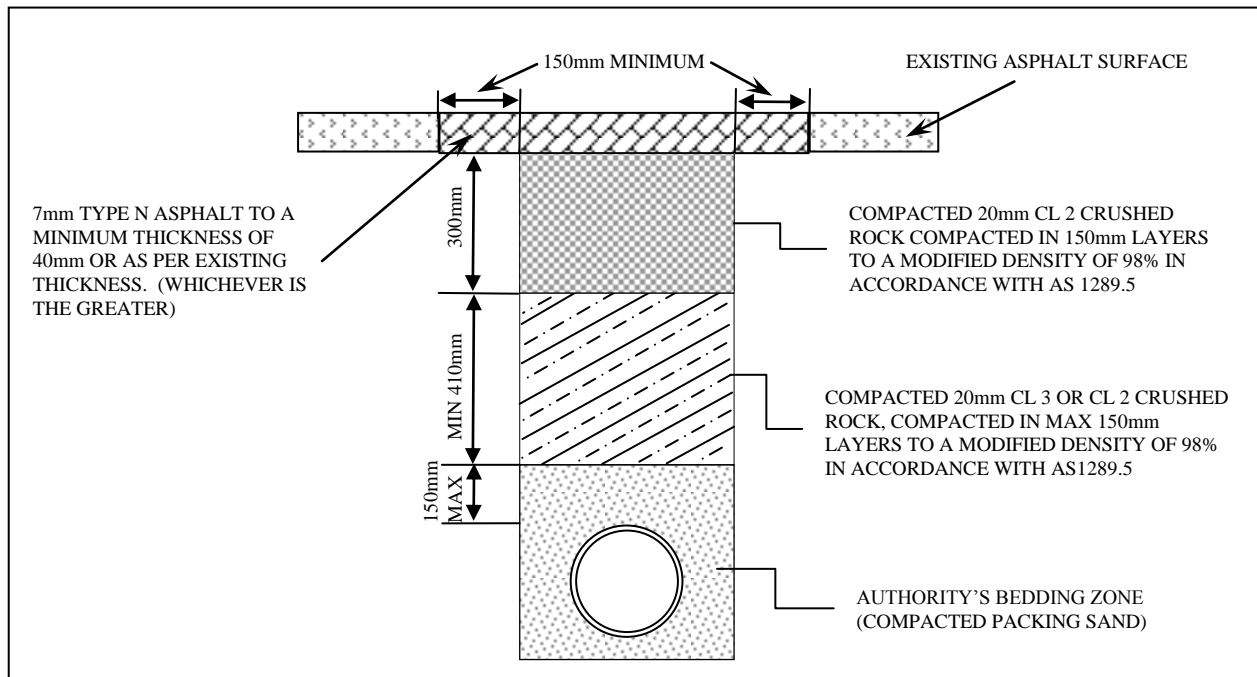

**Figure 8 Reinstatement of Trench through Asphalt Footpath**

### 6.2.2.2 Tolerance

The finished surface shall be true to level and grade of existing surrounding surfaces. The finished surface shall not deviate at any point more than 20mm from the bottom of a 3 metre straight edge.

### 6.2.3 Concrete

#### 6.2.3.1 Standard

All trenches shall have excavated material removed from site and backfilled with 20mm Class 3 Fine Crushed Rock (see Figure 9). The material shall be compacted by mechanical means in no more than 150mm layers.

It shall be compacted by mechanical means with optimum moisture to enable a minimum compaction of 95% Australian Standards 1289.5 and shall be finished to existing level and grade.

Only full bays shall be removed. No part bays are to be cut and removed unless approved by Council's Manager - Engineering Infrastructure.

All work must be formed true to line with existing concrete.

Care must be taken to fill every part of the forms without displacing them.

The concrete reinstatement shall span the finished trench width by not less than 150mm each side and be a complete bay. The thickness is to be the greater of 75mm or existing thickness of abutting bays. All bays are to be dowelled to join existing and reinforcement placed in accordance with the Infrastructure Design Manual. Dowell pin holes are to be a nominal 2mm  $\varnothing$  greater than the dowell pin and pins inserted no more than 80% depth of the hole to allow for thermal expansion.

For a period of 24 hours following the completion of any concreting done in adverse weather conditions, the work shall be covered with hessian or another suitable material to prevent damage in wet weather or similarly covered and kept wet to prevent cracking in abnormally dry conditions.

The surface shall have an even non-skid surface.

All edges of slabs shall be given a 10mm bullnose finish with approved edging tools to improve appearances and prevent chipping.

Concrete mix, 28 day strength, and reinforcement shall be in accordance with Appendix A – Infrastructure Design Manual. Concrete with a slump exceeding 100mm shall not be used.

Concrete shall only be stored for very short periods of time (less than twenty minutes) in self-cleansing hoppers with sides at an angle of at least 45° to the horizontal.

Colour to match that of existing concrete.

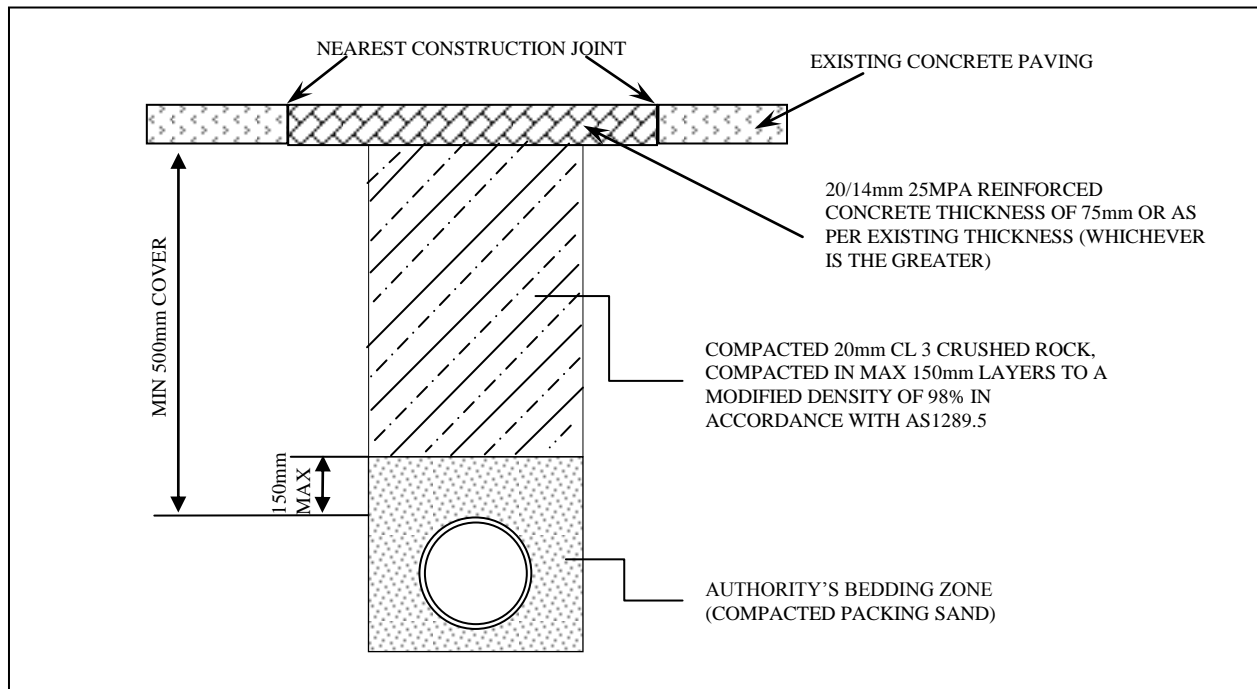

**Figure 9 Reinstatement of Trench through Concrete Footpath**

### 6.2.3.2 Standard Drawings

Refer to Appendix A – Infrastructure Design Manual.

### 6.2.3.3 Tolerance

The finished surface shall be true to level and grade of existing surrounding surfaces.

## 6.3 KERB AND CHANNEL

### 6.3.1 Concrete & Bluestone Channel

#### 6.3.1.1 Standard

All trenches shall have excavated material removed from site and backfilled with 20mm Class 2 Fine Crushed Rock. The material shall be compacted by mechanical means in no more than 150mm layers.

It shall be compacted by mechanical means with optimum moisture to enable a minimum compaction of 98% Australian Standards 1289.5. It shall be finished to existing level and grade.

The reinstatement of concrete kerb & channel must be pinned using N12 bar pins (min. of 3). Pins shall not be inserted less than 100 mm into existing concrete.

For a period of 24 hours following the completion of any concreting done in adverse weather conditions, the work shall be covered with hessian or another suitable material to prevent damage in wet weather or similarly covered and kept wet to prevent cracking in abnormally dry conditions.

Concrete shall only be stored for very short periods of time (less than twenty minutes) in self-cleansing hoppers with sides at an angle of at least 45° to the horizontal.

### 6.3.1.2 Standard Drawing

Concrete kerb and channel replacement shall be in accordance with the Infrastructure Design Manual.

All bluestone restoration shall be done in accordance with Appendix A – Infrastructure Design Manual and Appendix D – Bluestone pitcher channel.

### 6.3.1.3 Tolerance

The finished surface shall be true to level and grade of existing surrounding surfaces.

## 6.4 PROPERTY STORMWATER DRAINS

Where a utility company passes through a property stormwater drain, it shall be reinstated as such:

### 6.4.1 P.V.C.

It shall be replaced to the farther side of the service trench and neatly cut and joined with the appropriate size joiner (see Figure 10).

All joints shall be solvent glued.

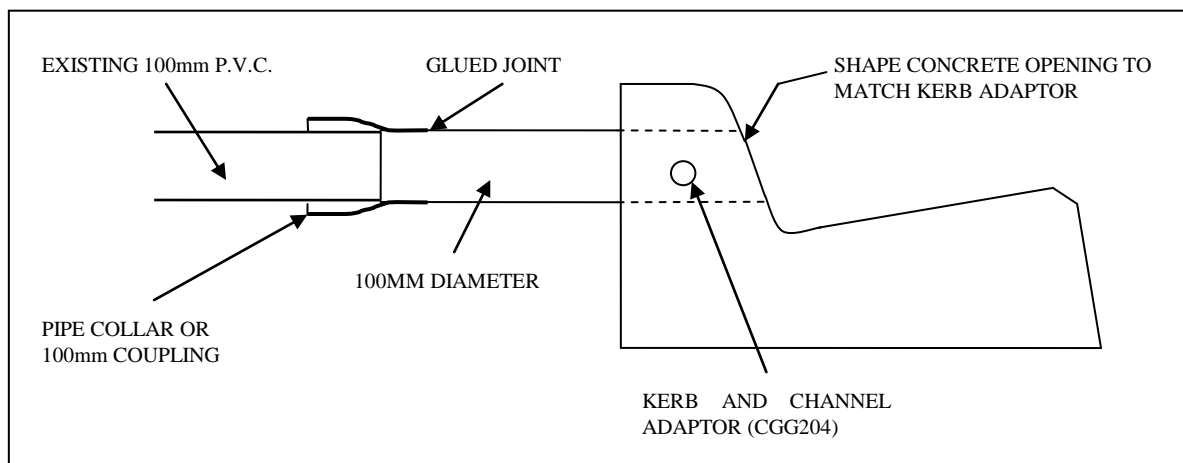

**Figure 10 P.V.C. Pipe Replacement Connection**

## 6.4.2 Earthenware

It shall be replaced to the side and the nearest join with a P.V.C. adapter shown in Figure 11.

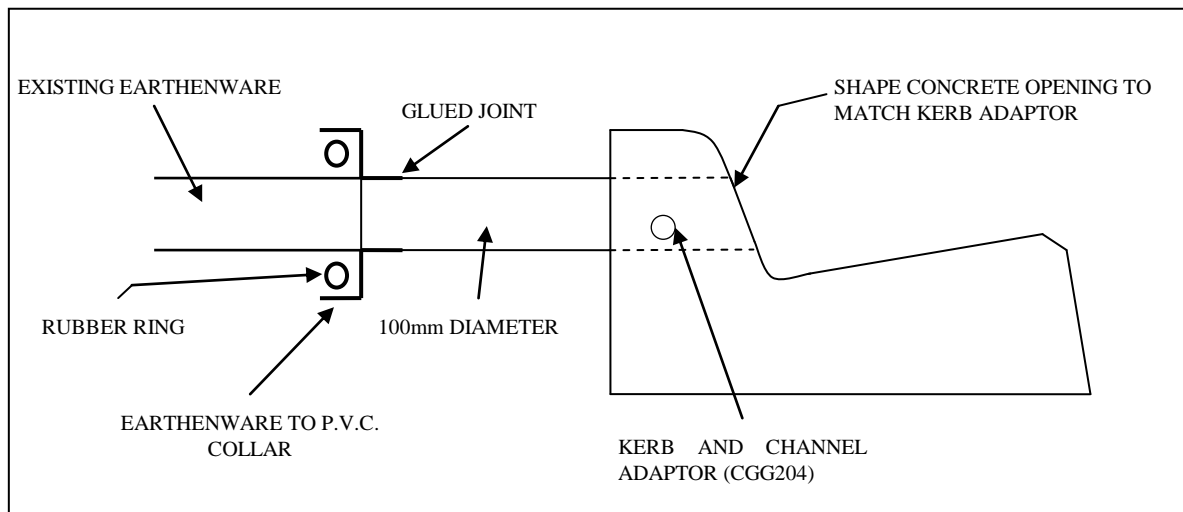

**Figure 11 Earthenware Pipe Replacement Connection**

## 6.5 DRIVEWAYS

### 6.5.1 Gravel

#### 6.5.1.1 Standards

All trenches shall have excavated material removed from site and backfilled with 20mm Class 3 Fine Crushed Rock (see Figure 12). The material shall be compacted by mechanical means in no more than 150mm layers with the final 150mm to be 20mm Class 2 Fine Crushed Rock or compacted material consistent with the surrounding driveway product, product used to match existing.

It shall be compacted by mechanical means with optimum moisture to enable a minimum compaction of 98% Australian Standards 1289.5. It shall be finished to existing level and grade.

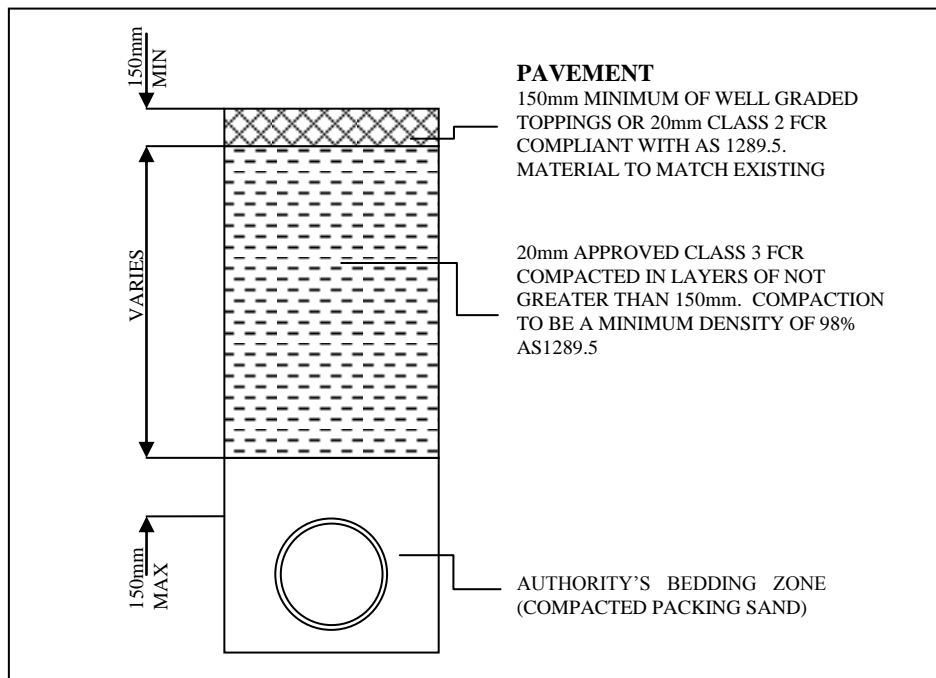

**Figure 12 Reinstatement of Trench through Gravel Driveway**

## 6.5.2 Asphalt

### 6.5.2.1 Standards

All trenches shall have excavated material removed from site and backfilled with 20mm Class 2 Fine Crushed Rock. The material shall be compacted by mechanical means in no more than 150mm layers.

It shall be compacted by mechanical means with optimum moisture to enable a minimum compaction of 98% Australian Standards 1289.5. It shall be finished to existing level and grade.

All asphalt openings prior to being reinstated shall be trimmed to provide a depth of 50mm for asphalt.

All asphalt placed shall be compacted by either steel wheeled roller or vibrating plate. The surface shall be smooth and durable for vehicular use.

All edges shall be treated with emulsion prior to the placement of asphalt.

## 6.5.3 Concrete

### 6.5.3.1 Standards

All trenches shall have excavated material removed from site and backfilled with 20mm Class 3 Fine Crushed Rock (see Figure 13). The material shall be compacted by mechanical means in no more than 150mm layers.

The reinstatement of concrete driveways must be pinned using R12 bar pins at 600mm centres. Pins shall not be inserted less than 150 mm into existing concrete.

All work must be formed true to line with existing concrete.

Colour to match that of existing concrete.

Care must be taken to fill every part of the forms without displacing them.

For a period of 24 hours following the completion of any concreting done in adverse weather conditions, the work shall be covered with hessian or another suitable material to prevent damage in wet weather or similarly covered and kept wet to prevent cracking in abnormally dry conditions.

The surface shall have an even non-skid surface.

All edges of slabs shall be given a 10mm bullnose finish with approved edging tools to improve appearances and prevent chipping.

Concrete mix, 28 day strength, and reinforcement shall be in accordance with the Infrastructure Design Manual (Appendix A). Concrete with a slump exceeding 100mm shall not be used.

Concrete shall only be stored for very short periods of time (less than twenty minutes) in self-cleansing hoppers with sides at an angle of at least 45° to the horizontal.

The concrete reinstatement shall span the finished trench width by not less than 300mm each side and be a complete bay.

Only full bays shall be removed. No part bays are to be cut and removed unless approved by Council’s Manager - Engineering Infrastructure.

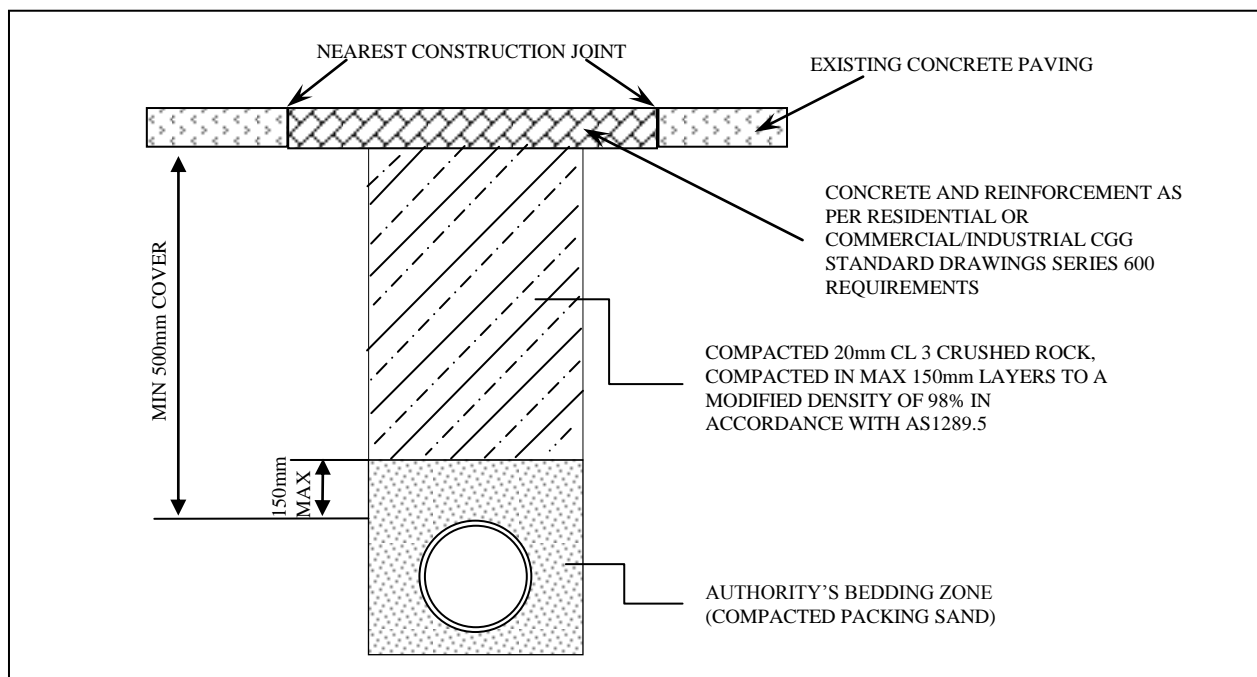

**Figure 13 Reinstatement of Trench through Concrete Driveway**

### **6.5.3.2 Standard Drawings**

Refer to Appendix A – Infrastructure Design Manual.

### **6.5.3.3 Tolerance**

The finished surface shall be true to level and grade of existing surrounding surfaces.

## **6.6 ROAD SHOULDERS**

### **6.6.1 Sealed**

All trenches shall have excavated material removed from site and backfilled with 20mm Class 2 Fine Crushed Rock. The material shall be compacted by mechanical means in no more than 150mm layers.

It shall be compacted by mechanical means with optimum moisture to enable a minimum compaction of 98% Australian Standards 1289.5. It shall be finished to existing level and grade.

All asphalt openings prior to being reinstated shall be trimmed to provide a depth of 50mm for asphalt.

All asphalt placed shall be compacted by either steel wheeled roller or vibrating place. The surface shall be smooth and durable for vehicular use.

All edges shall be treated with emulsion prior to the placement of asphalt.

Asphalt to be a nominal size 10 with type to match existing or as directed.

### **6.6.2 Unsealed**

All trenches shall have excavated material removed from site and backfilled with 20mm Class 2 Fine Crushed Rock. The material shall be compacted by mechanical means in no more than 150mm layers

It shall be compacted by mechanical means with optimum moisture to enable a minimum compaction of 98% Australian Standards 1289.5. It shall be finished to existing level and grade.

#### **6.6.2.1 Tolerances**

The finished surface shall be true to line, level, and grade as existing surface.

### 6.6.2.2 Standard Drawing

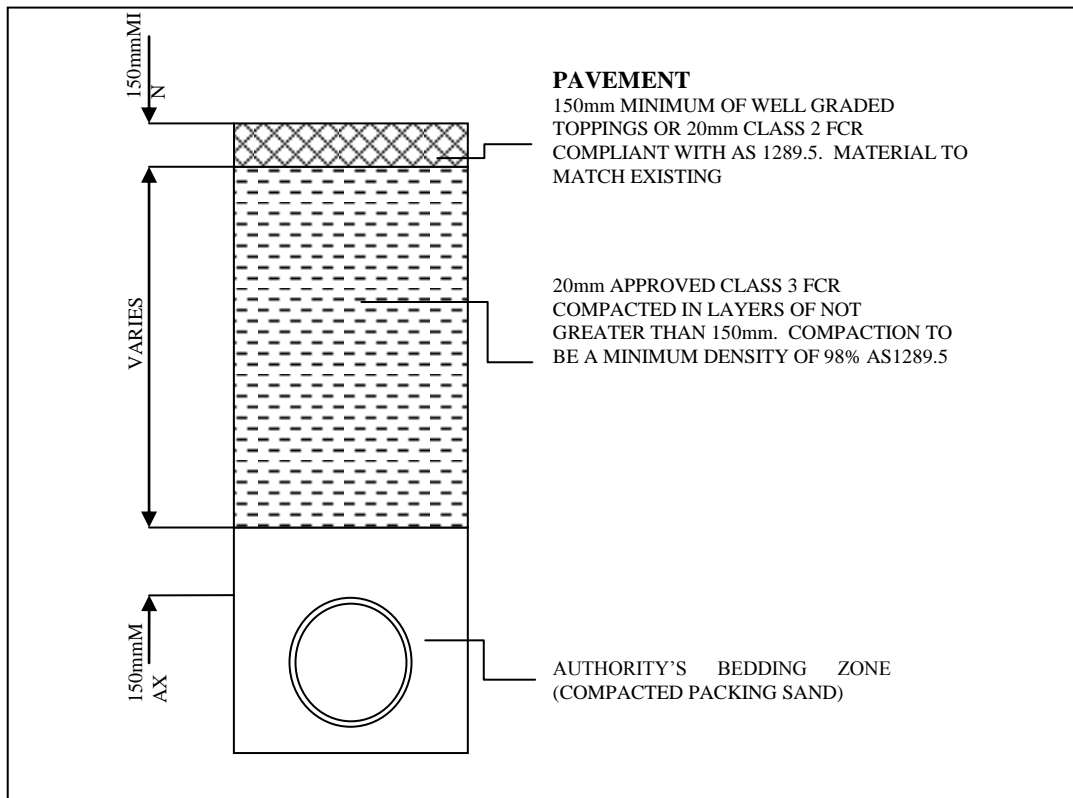

Figure 14 Unsealed Road Shoulder Reinstatement

## 6.7 ROADWAYS

### 6.7.1 Sealed

#### 6.7.1.1 Standards

All declared roads (list attached) are to be reinstated in accordance with VicRoads Standard Section 706 and Appendix I – Main Road Pavement Reinstatement

All Municipal road trenches shall have excavated material removed from site and backfilled with 20mm Class 2 Fine Crushed Rock. The material shall be compacted by mechanical means in no more than 150mm layers.

It shall be compacted by mechanical means with optimum moisture to enable a minimum compaction of 98% Australian Standards 1289 .5. It shall be finished to existing level and grade.

All asphalt openings prior to being reinstated shall be trimmed to provide a depth of 50mm for asphalt as selected from table 6.14 and advised by Council's Manager – Engineering Infrastructure.

All asphalt placed shall be compacted by either steel wheeled roller or vibrating plate. The surface shall be smooth and durable for vehicular use.

All edges shall be treated with emulsion prior to the placement of asphalt.

Asphalt to be a nominal size 10 with type to match existing or as directed.

**6.7.1.2 Standard Drawing**

**6.7.1.2.1 Declared Roads**

**Appendix I – Main Road Pavement Reinstatement**

**6.7.1.2.2 Municipal Roads**

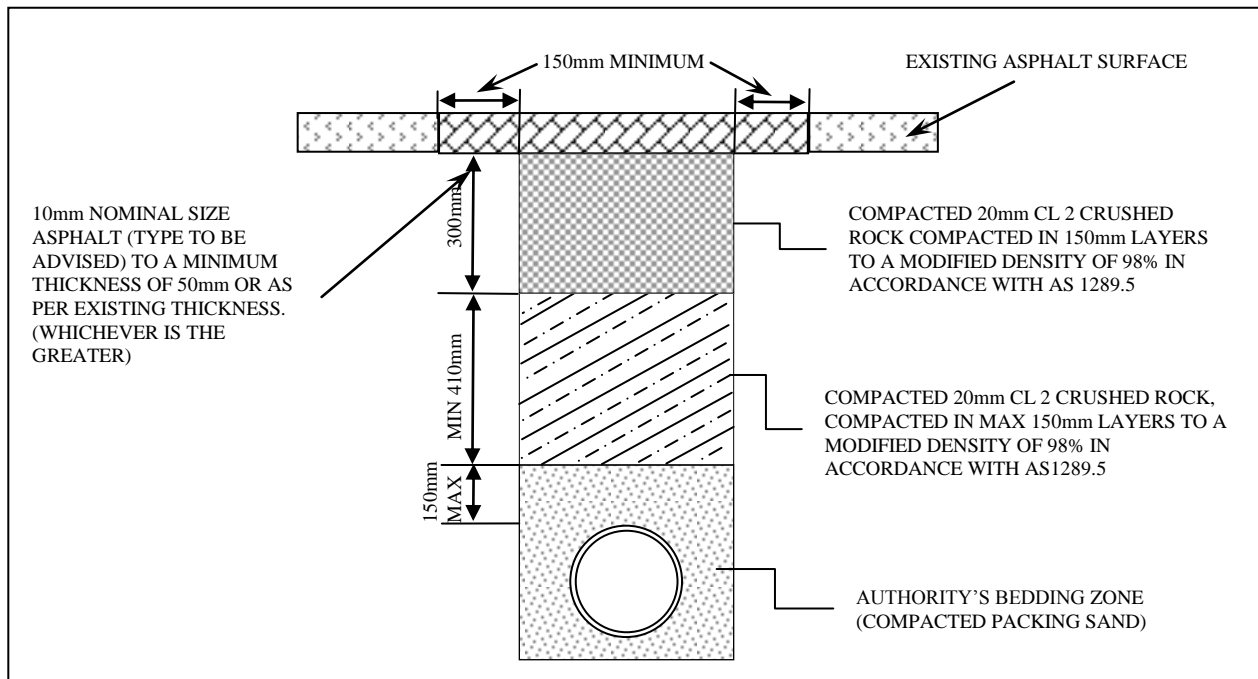

**Figure 15 Municipal Sealed Road Reinstatement**

**6.7.2 Unsealed**

**6.7.2.1 Standards**

All trenches shall have excavated material removed from site and backfilled with 20mm Class 2 Fine Crushed Rock. The material shall be compacted by mechanical means in no more than 150mm layers

It shall be compacted by mechanical means with optimum moisture to enable a minimum compaction of 98% Australian Standards 1289.5. It shall be finished to existing level and grade.

The finished surface shall be true to line and grade as existing surface.

## APPENDICES

### 6.8 APPENDIX A – INFRASTRUCTURE DESIGN MANUAL

Standard Drawings for road reserve infrastructure are available for download from the Infrastructure Design Manual website <http://www.designmanual.com.au/>

Reinstatements are required to conform to the standards set out in Infrastructure Design Manual, unless otherwise stated in this manual..

## 6.9 APPENDIX B - DECLARED ROADS LIST

### DECLARED ARTERIAL ROADS

Works on arterial roads require the consent of VicRoads under the Road Management Act 2004

### VIC ROADS CONTROL

DECLARED ROAD NAME	MUNICIPAL ROAD NAME	REFERENCE
<b>Bellarine Highway</b>	Ryrie Street	Latrobe Terrace to Swanston Street
	Sydney Parade	Swanston Street to Garden Street
	Ormond Road	Garden Street to Boundary Road
	Queenscliff Road	Boundary Road to Queenscliff
<b>Hamilton Highway</b>	Aberdeen Street	Latrobe Terrace to Gaylard Avenue
	Deviation Road	Gaylard Avenue to Hyland Street
	Hamilton Highway	Hyland Street to Friend in Hard Road
<b>Midland Highway</b>	Church Street	Pakington Street to Ballarat Road
	Ballarat Road	Church Street to Rollins Road
	Midland Highway	Rollins Road to Municipal boundary
<b>Princes Highway</b>	Princes Freeway	Little River Bridge to Corio overpass
	Princes Highway	Corio Railway Overpass to St. Georges Road
	Melbourne Road	St. Georges Road to Glenleith Avenue Overpass

DECLARED ROAD NAME	MUNICIPAL ROAD NAME	REFERENCE
	Keera Street	Glenleith Avenue to Latrobe Terrace Overpass
<b>Princes Highway (Cont'd)</b>	Latrobe Terrace	Rail Overpass to Barwon River
	Settlement Road	Barwon River to High Street
	Princes Highway	High Street to Pettavel Road
<b>Midland Highway</b>	Church Street	Pakington Street to Ballarat Road
	Ballarat Road	Church Street to Rollins Road
	Midland Highway	Rollins Road to Municipal boundary
<b>Princes Highway</b>	Princes Freeway	Little River Bridge to Corio overpass
	Princes Highway	Corio Railway Overpass to St. Georges Road
	Melbourne Road	St. Georges Road to Glenleith Avenue Overpass
	Keera Street	Glenleith Avenue to Latrobe Terrace Overpass
	Latrobe Terrace	Rail Overpass to Barwon River
	Settlement Road	Barwon River to High Street
	Princes Highway	High Street to Pettavel Road
<b>Surf Coast Highway</b>	Torquay Road	Settlement Road to Mt Duneed Road.
<b>Geelong-Portarlington Road</b>	Ryrie Street	Latrobe Terrace to Boundary Road
	Geelong-Portarlington Road	Boundary Road to Jetty Road
	High Street	Jetty Road to Murradoc Road
	Collins Street	Murradoc Road to Whitcombes Road
	Geelong-Portarlington Road	Whitcombes Road to Sproat Street

<b>DECLARED ROAD NAME</b>	<b>MUNICIPAL ROAD NAME</b>	<b>REFERENCE</b>
	Newcombe Street	Sproat Street to Harding Street
<b>Anglesea Road</b>	Anglesea Road	Princes Highway to Mt Duneed Road
<b>Bayside Main Road</b>	Corio Quay Road	McLeod Street to Station Street
	Bayside Road	Station Street to Seabeach Parade
	Seabeach Parade	Bayside Road to St Georges Road
	Low Street	St Georges Road to Wharf Road
	Wharf Road	Low Street to Shell Parade
	Shell Parade	(Wharf Road to Bell Road).
<b>Barrabool Road</b>	Barrabool Road	Shannon Avenue to Merrawarp Road
<b>Barwon Heads Road</b>	Barwon Heads Road	Settlement Road to Sheepwash Road
	Golf Links Road	Sheepwash to Bridge Road
	Bridge Road	Golf Links Road to Barwon River
<b>Barwon Heads-Ocean Grove Road</b>	Barwon Heads-Ocean Grove Road	Barwon River to Wallington Road
	Orton Street	Wallington Road to Hodgson Street
	Hodgson Street	Orton Street to The Parade
	The Parade	Hodgson Street to Tuckfield Street
<b>Belmont-Corio Main Road</b>	Shannon Avenue	Barrabool Road to Midland Highway
	Thompson Road	Midland Highway to Cox Road
	Cox Road	Thompson Road to Princes Highway
<b>Boundary Road</b>	Boundary Road	Geelong-Portarlington Road to Fellmongers Road
<b>Breakwater Road</b>	Breakwater Road	Settlement Road to Tucker Street
<b>Drysdale-Ocean Grove Road</b>	Grubb Road	Geelong-Portarlington Road to Shell Road

<b>DECLARED ROAD NAME</b>	<b>MUNICIPAL ROAD NAME</b>	<b>REFERENCE</b>
	Tuckfield Street	Shell Road to The Parade
<b>Drysdale-St Leonards Road</b>	Murradoc Road	Geelong-Portarlington Road to The Esplanade
<b>Fellmongers Road</b>	Fellmongers Road	Tucker Street to Boundary Road
<b>Forest Road South</b>	Forest Road South	Princes Highway to Station Lake Road
<b>Fyansford-Corio Main Road</b>	Hyland Street	Hamilton Highway to McCurdy Road
	McCurdy Road	Hyland Street to Church Street
	Church Street	McCurdy Road to Vines Road
	Vines Road	Church Street to Midland Highway
	Anakie Road	Midland Highway to Cox Road
	Cox Road	Anakie Road to Thompson Road
<b>Fyansford-Gheringhap Road</b>	Fyansford-Gheringhap Road:	Hamilton Highway to Dog Rocks Road
<b>Geelong-Bacchus Marsh Road</b>	Bacchus Marsh Road	Princes Highway to Balliang Creek
<b>Geelong-Ballan Road</b>	Geelong-Ballan Road	Midland Highway to Clarkes Road
<b>Fyansford-Gheringhap Road</b>	Fyansford-Gheringhap Road	Hamilton Highway to Dog Rocks Road
<b>Geelong-Bacchus Marsh Road</b>	Bacchus Marsh Road	Princes Highway to Balliang Creek
<b>Geelong-Ballan Road</b>	Geelong-Ballan Road	Midland Highway to Clarkes Road
<b>Lower Duneed Road</b>	Lower Duneed Road	Surfcoast Highway to Barwon Heads Road

<b>DECLARED ROAD NAME</b>	<b>MUNICIPAL ROAD NAME</b>	<b>REFERENCE</b>
<b>Newtown – Whittington</b>	West Fyans	Shannon Ave to Latrobe Terrace
<b>Newtown – Whittington (cont'd)</b>	Fyans Street	Latrobe Terrace to Wood St
	Carr Street	Wood St to Boundary Rd
<b>North Shore Road</b>	North Shore Road	Station Street to Princes Highway
<b>North Valley Road</b>	North Valley Road	Barrabool Road to Roslyn Road
<b>Pioneer Road</b>	Pioneer Road	Princes Highway to Surfcoast Highway
<b>Portarlington-Queenscliff Road</b>	Portarlington-Queenscliff Road	Portarlington-St Leonards Road to Bellarine Highway
<b>Portarlington-St Leonards Road</b>	Newcombe Street	Harding Street to Fisher Street
	Fisher Street	Newcombe Street to Portarlington-Queenscliff Road
	Hood Road	Portarlington-Queenscliff Road to The Esplanade
	The Esplanade	Hood Road to Murradoc Road
<b>Queens Park Road</b>	Aphrasia Street	Shannon Avenue to Layton Crescent
	Queens Park Road	Layton Crescent to Buckley Falls Road
	Scenic Road	Buckley Falls Road to Barrabool Road
<b>Separation Street</b>	Separation Street	Princess Hwy to Anakie Road
<b>South Valley Road</b>	South Valley Road	Barrabool Road to Princes Highway
<b>Station Street</b>	Station Street	Corio Quay Road to Princes Hwy
<b>St Georges Road</b>	St Georges Road	Princes Hwy to Seabeach Parade
<b>Steiglitz Road</b>	Steiglitz Road	Ballan Road to Hopes Bridge
<b>The Boulevard</b>	The Boulevard	Princes Highway to Morgan Street

<b>DECLARED ROAD NAME</b>	<b>MUNICIPAL ROAD NAME</b>	<b>REFERENCE</b>
<b>Tucker Street</b>	Tucker Street	Breakwater Road to Fellmongers Road

## **6.10 APPENDIX C - ASPHALT SELECTION GUIDE**

**GUIDE FOR SELECTION OF DENSE GRADED ASPHALT TYPES (VicRoads Technical Note 3 – May 2006)**

Course	AADT / Lane <sup>(2)</sup>		Designation <sup>(1)</sup>		Binder Class	Minimum PSV	Standard Mix Sizes <sup>(3)</sup>	Remarks
	HV's	Total	Current	Former				
Wearing	< 25	< 500	L	L	C170 or C320	-	7 & 10	C170 binder must be used if mix contains more than 10% RAP
	25 – 300	500 – 3000	N	N	C170 or C320	-	7, 10 & 14	C170 binder must be used if mix contains more than 10% RAP
	> 300	> 3000	H	H	C320	48	10 & 14	Standard heavy duty wearing course
	> 500	> 5000	V <sup>(4)</sup>	V	C320	54 <sup>(6)</sup>	10 & 14	Restricted to signalized intersections and roundabouts
	> 1000	> 10000	HG <sup>(4),(5)</sup>	-	M (600/170)	48 <sup>(6)</sup>	10 & 14	
Structural	> 200 <sup>#</sup>	> 2000 <sup>#</sup>	HP <sup>(4)</sup>	H <sub>m</sub>	PMB (A10E)	48 <sup>(6)</sup>	10 & 14	For medium and heavy duty use. Specialist advice should be sought.
	25 – 1000	500 – 10000	SI	T	C320	-	14 & 20	Standard Structural Mix. Generally Size 20
	> 1000	> 10000	SS	T (600)	C600	-	20	
	> 1000	> 10000	SG <sup>(3)</sup>	-	M (600/170)	-	20	
	> 1000	> 10000	SI	T	C320	-	20	Type SS preferred within 100mm of finished surface level (excluding OGA) for freeways and large scale works
Base	> 1000	> 10000	SP	T <sub>m</sub>	PMB (A10E)	-	20	Alternative PMB Class may be appropriate. Specialist advice should be sought prior to use.
	All	All	SI	T	C320	-	20	Standard Structural Mix
	All	All	SF	R	C320	-	20	Min. Layer thickness of 75mm and Min. Cover of 100mm of DGA is required

(1) Standard Types of Dense Graded Asphalt (DGA)

- L** A light duty Size 7 or 10 wearing course with low air voids and higher binder wearing course for use in very lightly trafficked pavements.
  - N** A light to medium duty Size 7, 10 or 14 wearing course for use in light to moderately trafficked pavements
  - H** A heavy duty Size 7, 10 or 14 asphalt wearing course for use in most heavily trafficked pavements.
  - V** A heavy duty Size 10 or 14 asphalt wearing course for heavily trafficked intersections.
  - HG** A multi purpose heavy duty to Size 10 or 14 wearing course asphalt incorporating multi-grade binder where a high resistance to deformation is required, particularly at heavily trafficked intersections.
  - HP** A high performance Size 10 or 14 heavy to very heavy duty wearing course asphalt incorporating a Polymer Modified Binder (PMB) where a high resistance flexural cracking and/or deformation is required.
  - SI** A multi purpose Size 14 or 20 structural asphalt for intermediate course in heavy duty pavements or base course in medium duty pavements.
  - SS** A very stiff and rut resistant Size 20 structural intermediate course asphalt often used for large scale heavy duty asphalt pavements.
- SG** A multi purpose heavy duty Size 20 structural intermediate course asphalt incorporating a multi-grade binder for high resistance to deformation particularly at very heavily trafficked intersections.
- SP** A high performance heavy to very heavy duty Size 20 structural intermediate course asphalt incorporating a PMB for high resistance to deformation and flexural cracking.
- SF** A fatigue resistant Size 20 structural base course asphalt for heavy duty asphalt pavements with a total asphalt thickness in excess of 175 mm.
- (2) Greater priority should be given to the volume of Heavy Vehicles (HVs) if known.
- (3) The nominal size of asphalt should be compatible with the layer thickness as follows:
- | Size (mm) | Thickness Range (mm) | Recommended (mm) |
|-----------|----------------------|------------------|
| 7         | 15 – 25              | 20               |
| 10        | 25 – 35              | 30               |
| 14        | 35 – 50              | 40               |
| 20        | 50 – 100             | 75               |
- (4) Where Type V, HG or HP is recommended for use at intersections, it should commence at the start of the turn lane taper (or a minimum of 80 m from the stop line) and extend through the intersection and the first 30 m of the departure lanes.
- (5) The supply of multi-grade binder is limited in Victoria. Consider alternatives.
- (6) PSV ≥ 54 must be used at high accident risk sites if available and economically feasible.

## **6.11 APPENDIX D – BLUESTONE PITCHER CHANNEL**

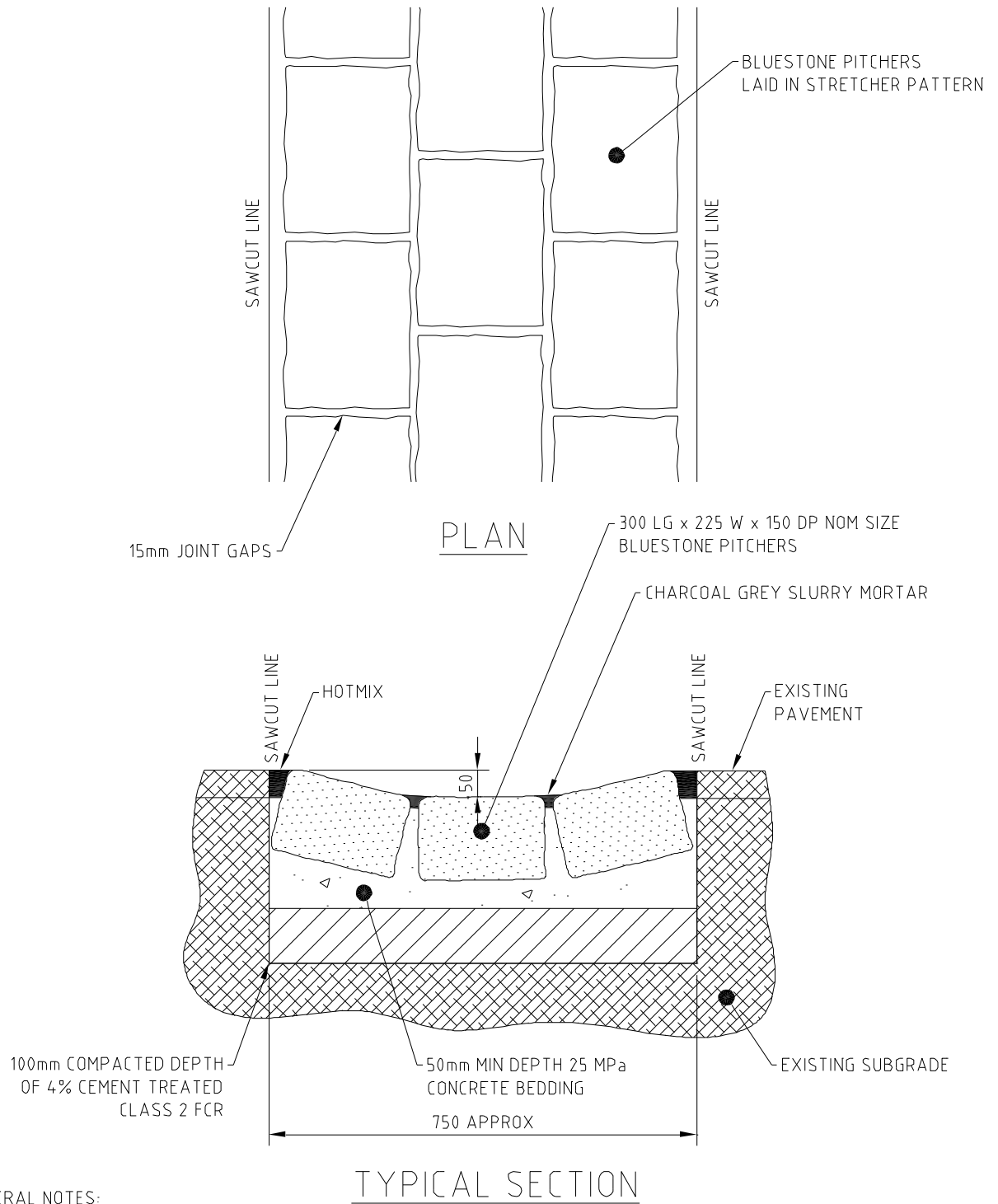

GENERAL NOTES:

1. PITCHERS TO BE LAID IN STRETCHER BOND PATTERN
2. DAMAGED AND UNSUITABLE BLUESTONE PITCHERS TO BE REPLACED / NOT USED
3. ALL JOINTS BETWEEN PITCHERS TO BE NO GREATER THAN 15mm WIDE
4. ALL MORTAR JOINTS TO HAVE A BRUSHED FINISH
5. THE NEED FOR AN A.G PIPE TO BE DETERMINED BY CONTRACT SPECIFICATION OR SUPERVISING ENGINEER
6. ALL BLUESTONE EDGING MUST HAVE A STRAIGHT ALIGNMENT. STRING LINES MUST BE SET UP FOR APPROVAL BY THE SUPERVISING ENGINEER PRIOR TO COMMENCEMENT

BLUESTONE PITCHER CHANNEL

**6.12 APPENDIX E – BLUESTONE KERB AND CONCRETE CHANNEL (MAJOR WORKS)**

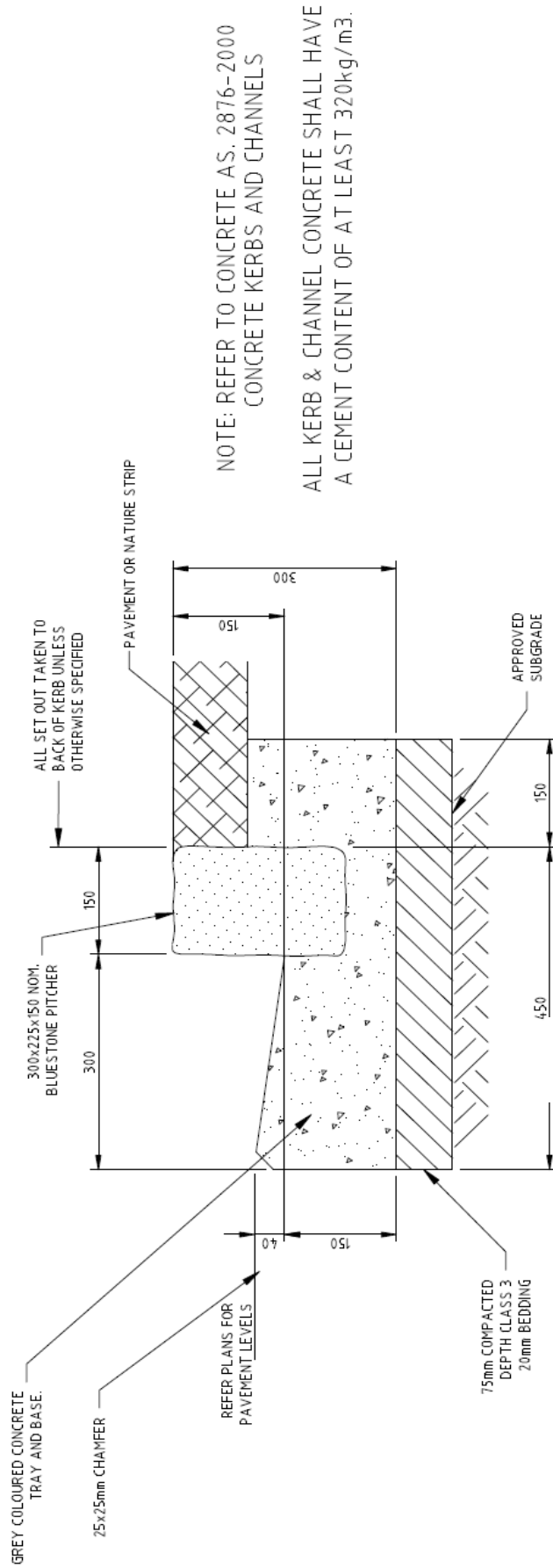

NOTE: REFER TO CONCRETE AS. 2876-2000 CONCRETE KERBS AND CHANNELS

ALL KERB & CHANNEL CONCRETE SHALL HAVE A CEMENT CONTENT OF AT LEAST 320kg/m<sup>3</sup>.

TYPICAL SECTION

SCALE 1:10

- NOTES:
1. GENERALLY TO BE USED IN MAJOR RE-INSTATEMENT WORKS
  2. REQUIRES APPROVAL BY COUNCIL HERITAGE OFFICER IN HERITAGE DESIGNATED AREAS.

## **6.13 APPENDIX F – BLUESTONE KERB AND CHANNEL (MINOR WORKS)**



## **6.14 APPENDIX G – VEHICLE CROSSINGS BLUESTONE KERB AND CHANNEL**

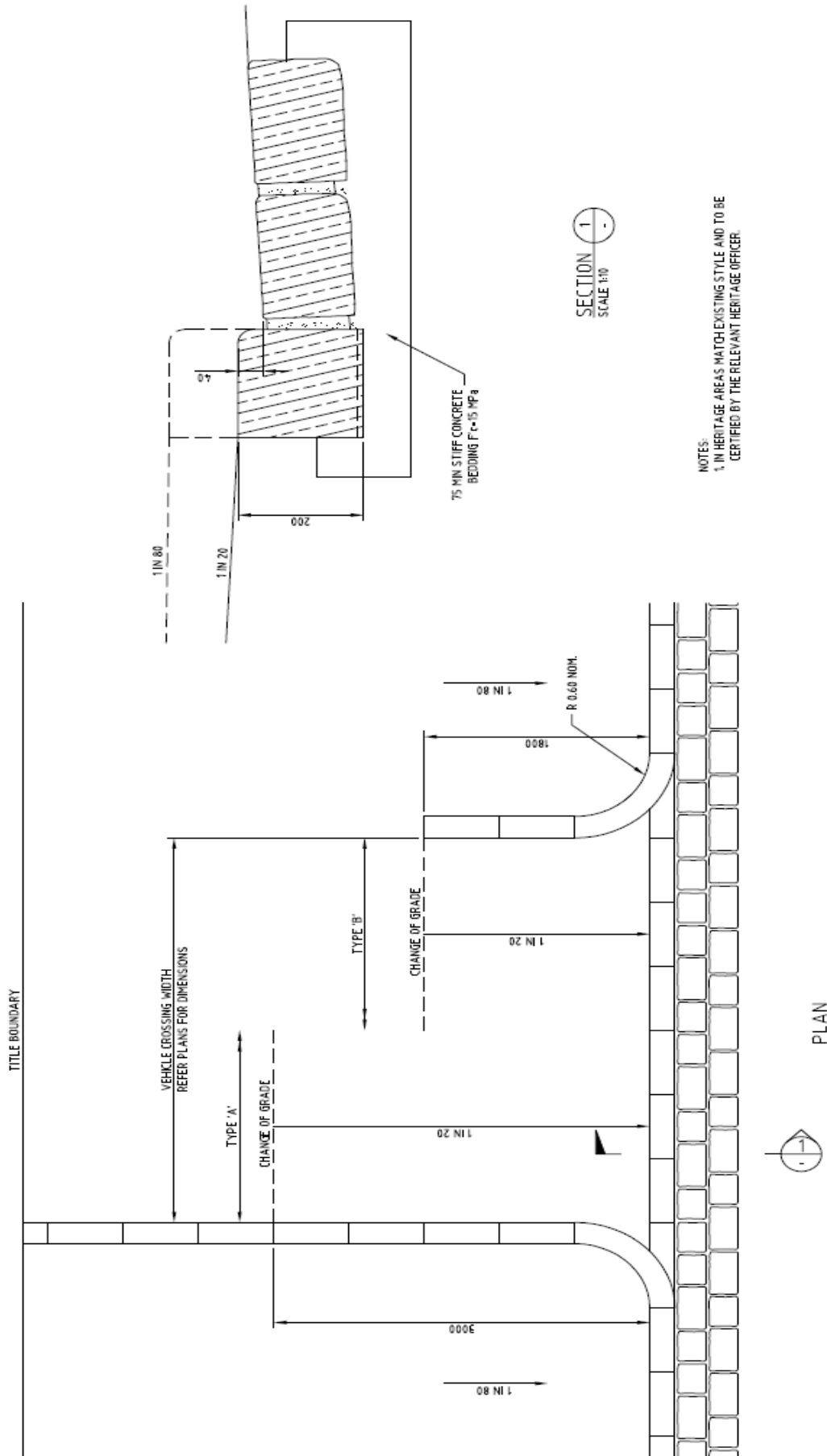

## **6.15 APPENDIX H – PEDESTRIAN CROSSING BLUESTONE KERB AND CHANNEL**

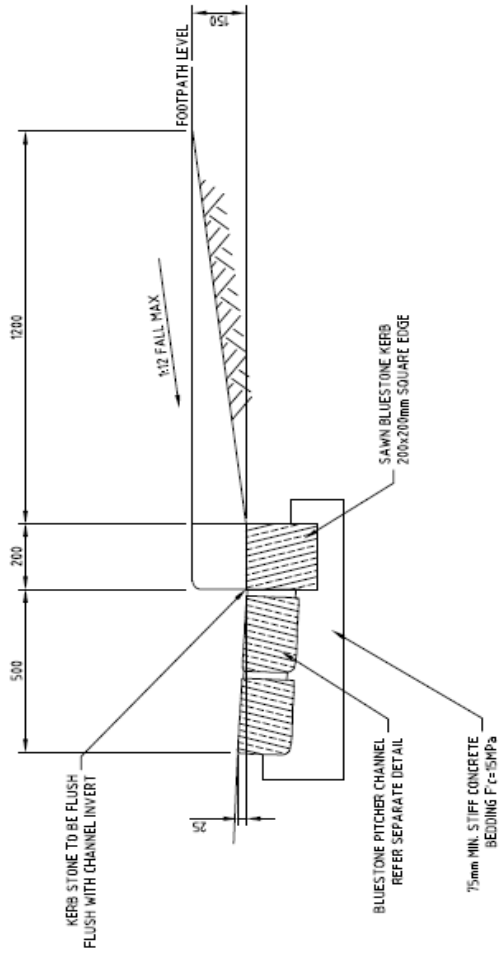

TYPICAL SECTION

NTS

- NOTES:
1. IN HERITAGE AREAS MATCH EXISTING STYLE AND TO BE CERTIFIED BY THE RELEVANT HERITAGE OFFICER.
  2. REFER TO AS 1428.4 FOR ODA COMPLIANCE.

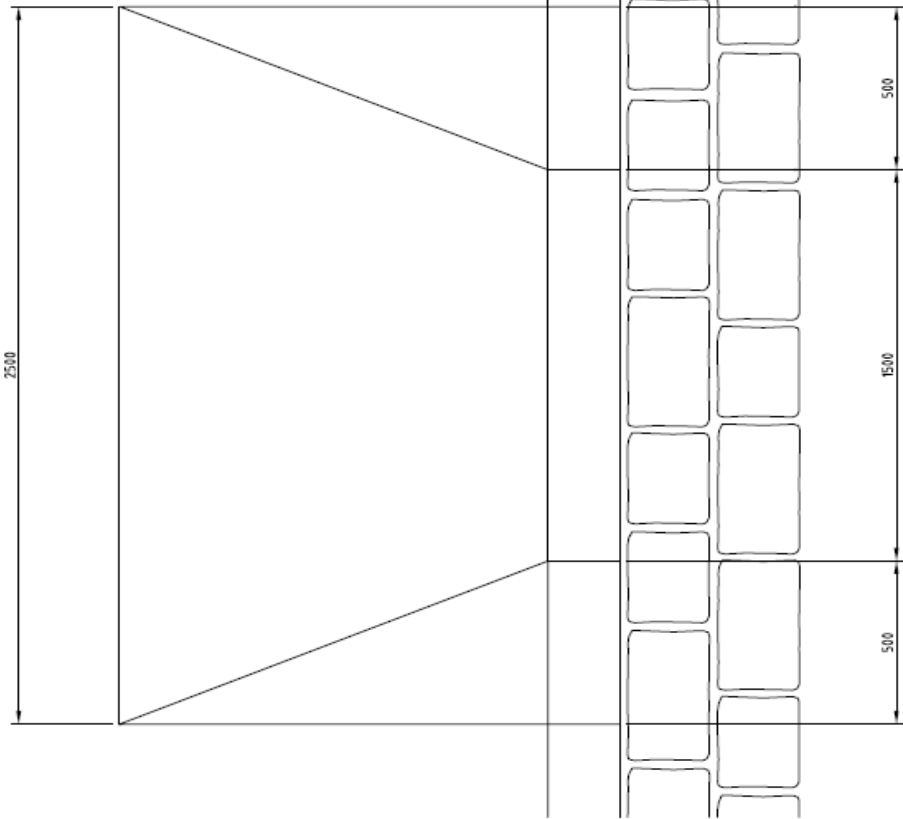

PLAN

NTS

## 6.16 APPENDIX I – MAIN ROAD PAVEMENT REINSTATEMENT

### MAIN ROAD PAVEMENT REINSTATEMENT METHOD Typical back fill for trenching works

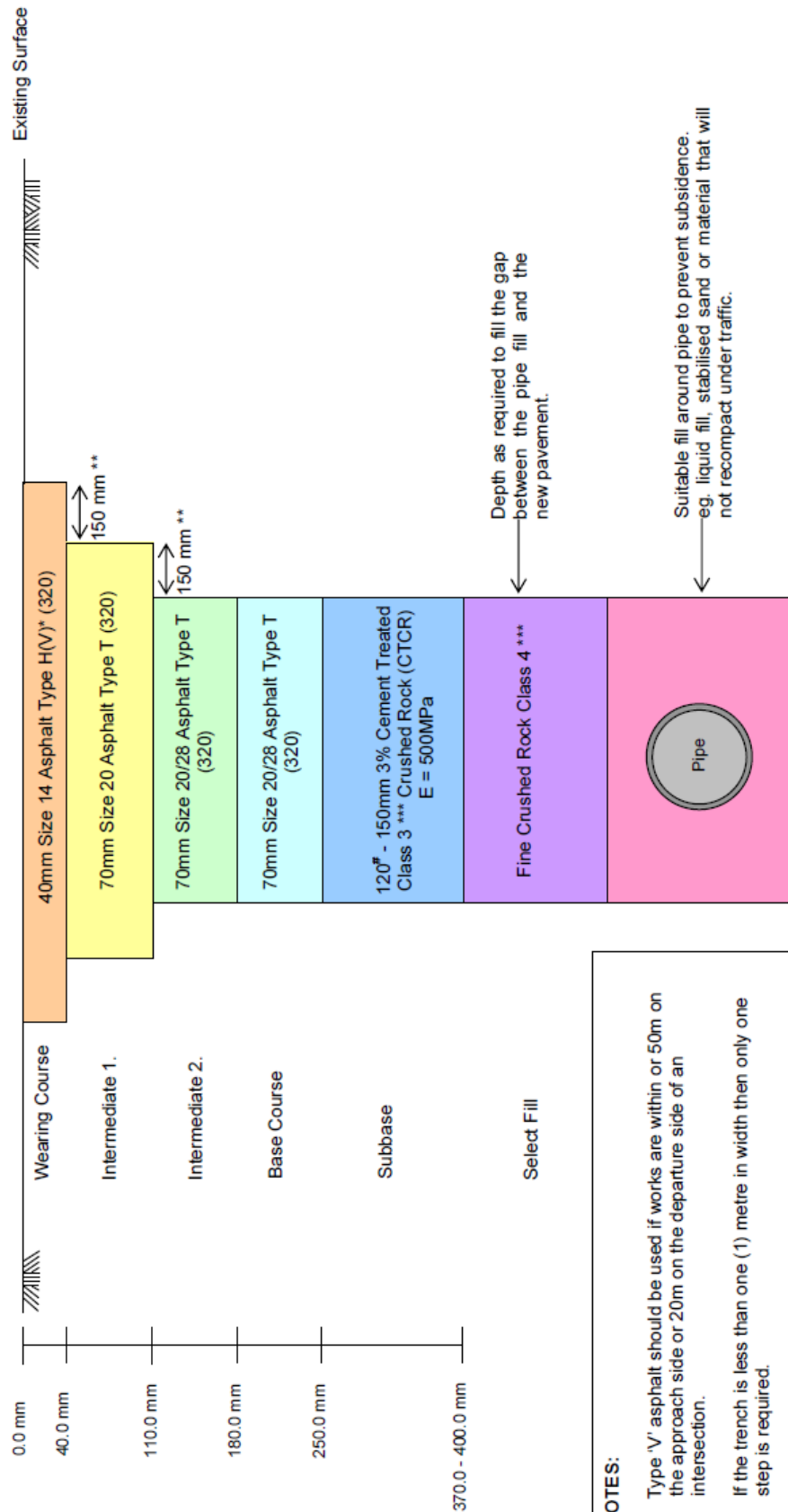

- NOTES:**
- \* Type 'V' asphalt should be used if works are within or 50m on the approach side or 20m on the departure side of an intersection.
  - \*\* If the trench is less than one (1) metre in width then only one step is required.
  - \*\*\* Type 'T' asphalt can be substituted for these layers for expediency.
  - # 120mm CTCR only for Main Roads with less than 2% Commercial Vehicles

