

TGSI – Tactile Ground Surface Indicators

Introduction:

This Design Note, No 11, provides guidelines and requirements for the use and installation of Tactile Ground Surface Indicators (TGSI's).

References

- Disability Discrimination Act 1992.
- Disability (Access to Premises) Standards 2010.
- Design for Access and Mobility
 - Part 1: General requirements for access – New building work AS – 1428.1 2009.
- Design for Access and Mobility
 - Part 4.1: Means to assist the orientation of people with vision impairment - Tactile ground surface indicators – AS/NZS 1428.4.1 2009
- VicRoads Road Design Note
 - Guidelines for the placement of Tactile Ground Surface Indicators (February 2005).
- Traffic Engineering Manual
 - Volume 1 Chapter 4 – September 2008
 - Volume 2 Chapter 21 – December 2001
- Road Safety Road Rules 2009
- Infrastructure Design Manual
 - Clause 13 Mobility and Access Provisions
- Central Geelong Public Realm Strategy

Definitions

- **Accessible**
Term used to describe the access component of a site, building or facility which complies with AS1428 (Various sections) the Disability Discrimination Act 1992 and the Disability (Access to Premises – Buildings) Standards 2010.
- **Activity Centre**
Activity Centres are defined as any place that attracts people for shopping, working, studying, recreation or socialising” (Department of Sustainability and Environment, 2002). It is predominantly a mixed-use urban area with a concentration of commercial and other land uses. (eg. Geelong Central Activities Area (CAA), suburban strip shopping centres)
- **Carriageway**
That portion of a road or bridge devoted particularly to the use of vehicles, inclusive of shoulders and auxiliary lanes. It is usually designated as that part of a public road (way) between kerbs
- **Project Manager**
Council officer assigned to design and / or construct works.

- **Ramp**
An inclined access way with a gradient steeper than 1 in 20 but not steeper than 1 in 14, with landings at spacing of between 15m and 9m relative to the gradient of the ramp. Note: For requirements for TGSIs, see AS1428.4.1:2009
- **Responsible Department**
The area of Council responsible for the specification and approval of TGSIs usage within an asset area.
- **Tactile Ground Surface Indicators (TGSIs)**
Truncated cones and/or bars installed on the ground or floor surface, designed to provide pedestrians who are vision-impaired with warning or directional orientation information.
- **Vehicle Crossing**
A vehicle crossing is the portion of a property's driveway located between the edge of the road and the property boundary.
- **Vision impairment**
A reduced vision that is not correctable by glasses or medication.

Approvals

Approvals for the installation of TGSIs will be at the discretion of the Responsible Department and in line with this Design note.

TGSIs General Requirements

In addition to other requirements the following apply

- (a) Directional TGSIs shall be laid so that there is no likelihood of the edges lifting.
 - (b) Where directional TGSIs are placed across the direction of travel, to ensure they are detected, they shall extend over a depth of 600 mm to 800 mm.
 - (c) A directional TGSIs shall be slip-resistant
 - (d) Directional TGSIs shall have the top surface no more than 4 mm to 5 mm above the base surface [see Figure 3.1(b)].
 - (e) The base surface of an integrated directional TGSIs shall be not more than 3 mm above the abutment surface of the surrounding floor or ground surface, and shall have all exposed external edges chamfered.
- (a) Warning tactile indicators should be located at crossing entry points and should be installed for the full width of the path of travel

Uniqueness of sites

Each site is unique and there is no one size fits all. The Project Manager and designer shall examine the constraints presented by the site, use the relevant standards as a basis, consult with relevant stakeholders as required and develop a TGSIs arrangement to suit. The responsible department shall review and approve the proposed arrangement. Guidelines to assist in the preparing of arrangements can be found in the VicRoads Road Design Note – Guidelines for the placement of tactile ground surface indicators and AS/NZS 1428.4.1:2009 – Design for access and mobility.

Priority locations

Installation of TGSIs will be undertaken as appropriate in conjunction with new infrastructure as well as a program to retrofit existing infrastructure.

The priority for installation of TGSIs in both areas will be given to areas of high pedestrian activity and where persons with vision impairment are likely to frequent. These areas include;

- Activity centres
- Public transport stops (responsibility of Public Transport Victoria)
- Signalised intersections
- Signalised pedestrian crossings
- Special need schools

A simple flow chart to assist in identifying if a site requires TGSIs is included in Appendix 1.

Assessment of Sites

Where practical the design of infrastructure should minimise the need for TGSIs to be installed, without compromising the needs of other users.

Pedestrian priority at vehicle crossings and carpark entries is defined in the Victorian Road Safety Road Rules. In order to minimise confusion between the driver and pedestrian regarding priority, the use of TGSIs on vehicle crossings and carparks shall be limited to high volume public carparks in activity centres' which meet the following criteria:

1. The driver's vision of a pedestrian is obstructed by a building or wall; and
2. The vehicle crossing by design operates as a defacto carriageway.

A driver's vision will be taken to be obstructed by a building or wall if whilst travelling at 10km/hr the driver would not safely be able to avoid a collision with a pedestrian when exiting the carpark. Evaluation of a driver's ability to avoid the collision can be obtained by matching features on the subject site to those shown in Figure 1 below

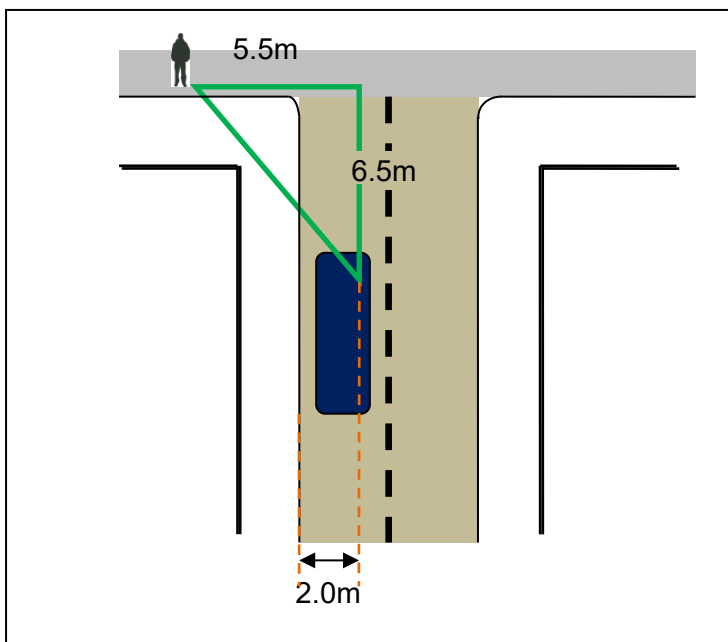
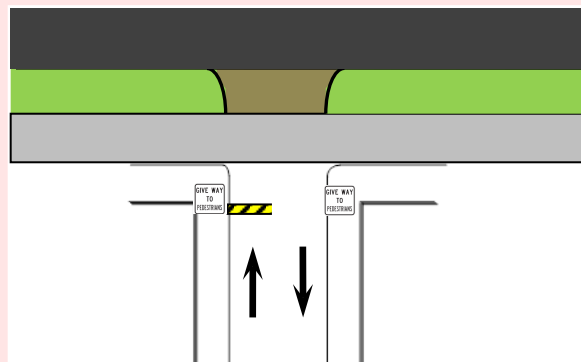

Figure 1 Required Stopping Sight Distance at 10km/hr

High Volume Carpark Vehicle Crossings

Where high volume carpark with vehicle crossings which do not meet the sightline requirements for the installation of TGSi exist, consideration needs to be given to providing clear visual definition to drivers that pedestrians have right of way as required under the Victorian Road Safety Road Rules. TGSi in these circumstances do not substitute for the rights or limited road safety comprehension of a child and engineering treatments must be directed towards the driver.

Potential options may include, but are not limited to, the use of narrow bolt down speed humps on the property side of the crossing, coloured approach pavements, illuminated 'give way to pedestrian' signs and/or a zebra crossing (where proven by warrants and authorised by the responsible authority).



Median Crossings

Raised islands in crossings should be cut through level with the street or have kerb ramps at both sides and a level area at least 1200 mm long in the part of the island intersected by the crossings

TGSIs should be provided at medians under the following circumstances:

- (a) Path of travel changes between the median and outer road edge kerb ramp
- (b) Major traffic control pedestrian facility exists, for traffic lights a pedestrian button must be present in the median
- (c) Kerb ramps are provided with 1200mm long level area between
- (d) Median is separating a multi-lane road

Roundabouts

Well designed roundabouts provide significant road safety benefits for drivers, however, they alter the normal right-of-way priority between a pedestrian and driver. In rural areas or urban residential areas with low volumes and vehicle speeds this altered right-of-way may not cause difficulty for pedestrians negotiating the intersection and no additional cues may be necessary. In the following circumstances though, the use of TGSi at a roundabout is considered advisable to improve the situational awareness of the hazards confronting visually impaired pedestrians:

- Location is an Urban Arterial Road
- Location is an Urban Collector Roads Category 4
- Location is an Urban Collector Roads Category 3, where post development vehicle volumes are expected to exceed 3000vpd
- Roundabout has concrete splitter islands with change of pedestrian crossing direction between island and kerb ramps

Warning of hazards within the circulation space, or adjacent to a continuous accessible path of travel

Where there are impediments or hazards with less than 2000 mm height clearance in an accessible open public space with no clearly defined continuous accessible path of travel (e.g., areas under a stairway, escalator or moving walkway), contact with overhead hazard shall be prevented by a suitable barrier such as—

- (a) enclosing the area; or
- (b) providing handrails with kerbs or kerb rails in accordance with AS 1428.1, see Figures 2.6(A)].

In the absence of a suitable barrier, TGSIs shall be installed as shown in AS1428.4.1 Figures 2.6(B).

Types of materials to be used

Pathfinder Polyurethane High Luminance Tactile Ground Surface Indicators (bladed shaft or star shaft type) or ESP Access Tile Tactile Ground Surface Indicators (surface applied only) on a concrete base, shall be used for all new TGSi installations outside of the Central Activity Area. TGSi installation within the Central Activity Area shall be Pathfinder Polyurethane High Luminance Tactile Ground Surface Indicators (bladed shaft or star shaft type) unless otherwise required by the Central Geelong Public Realm Strategy.

Product selection for replacement of existing TGSi's will be made on a case by case basis with the approval of the responsible department taking into account the existing material, product cost and ongoing maintenance. Where ceramic type TGSi are to be replaced, use of the ESP Access Tile (surface applied only) should be considered as an expedient alternative to full excavation of existing pathways. The hollow from the removed ceramic should be filled with high strength non shrink grout when in concrete or a new 100mm reinforced concrete bed prepared in asphalt surfaces before installation of the ESP Access Tile System by an accredited installer.

Previous experience using a range of other materials and providers has proven the durability, superiority, ease of installation and cost effectiveness of Pathfinder Polyurethane High Luminance TGSi's for new installations. The Surface Applied ESP Access Tile provides a stable, rapid replacement option for ceramic tiles.

Other new materials and products will be reviewed by Council's Engineering Standards Committee prior to inclusion as an alternative to the Pathfinder system or ESP Access Tile system.

TGSi installation by State Government Departments, where they maintain liability and maintenance for the installation, will be in accordance with the relevant standards and requirements they subscribe to. Where installations are to be managed and maintained by Council they shall meet Council's standards.

TGSi Installation

TGSi installations shall be undertaken by a trained installer conversant with the current standards and requirements. Where the ESP Access Tile system is used installation shall only be undertaken by an ESP accredited installer and a certificate of warranty provided to the City at handover.

Incorrectly installed TGSi shall be replaced to the satisfaction of the Responsible Department including repair of any damage to the underlying path at the installer's expense.

Colour Scheme

After evaluation of a number of different colours and consultation with advocacy groups for the vision impaired, the preferred colour scheme for use in the municipality, excluding the Central Activity Area, is:

Black: to be used on concrete and light-coloured surfaces (including pavers)

Yellow: to be used on plain and exposed aggregate concrete, asphalt, charcoal concrete and dark coloured surfaces.

Alternative colours cobalt blue, beige/ivory and stainless steel may be considered in areas of strategic importance or where colour luminescence contrast requirements are not met by the standard colours and with the prior approval of the Responsible Department.

The selection of colours within the Central Activity Area is governed by the Central Geelong Public Realm Strategy. The strategy identifies the following colours:

Stainless Steel: to be used in asphalt paved areas.

Granite: to be used in bluestone paved areas.

Other guidelines

The following figures provide a guide to installing TGSi within the road reserve. Additional diagrams are provided in AS1428.4.1.

Figure 2 Right Angle Intersection

< 3000mm from property boundary to top of ramp
For kerb ramp gradients of 1:8.5 or steeper

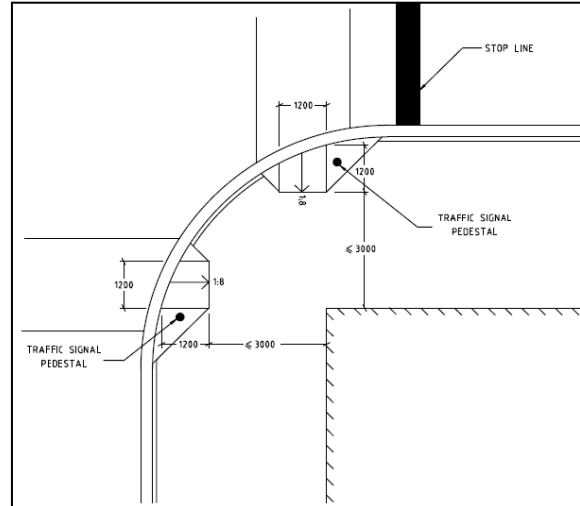

Figure 3 Right Angle Intersection

< 3000mm from property boundary to top of ramp
For kerb ramp gradients flatter than 1:8.5

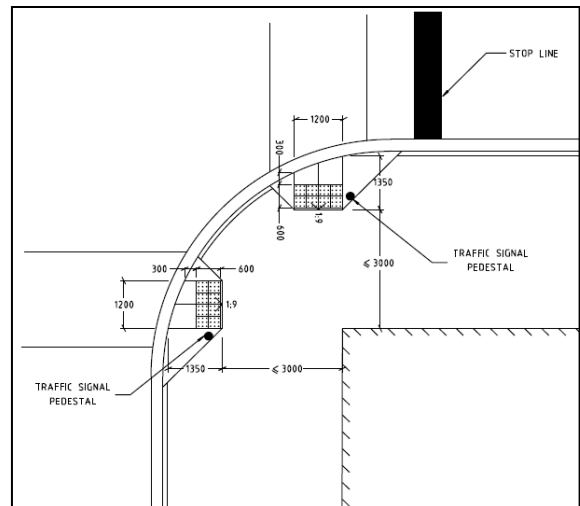

Figure 4 Right Angle Intersection

> 3000mm footway
1:8 kerb ramp gradient

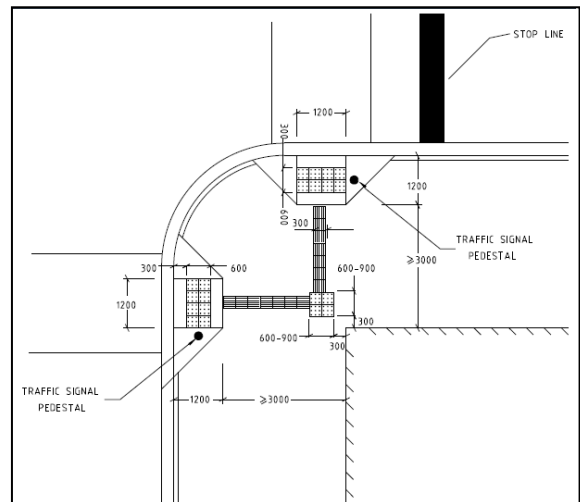

Figure 5 Mid-block crossing

1:8 kerb ramp gradient

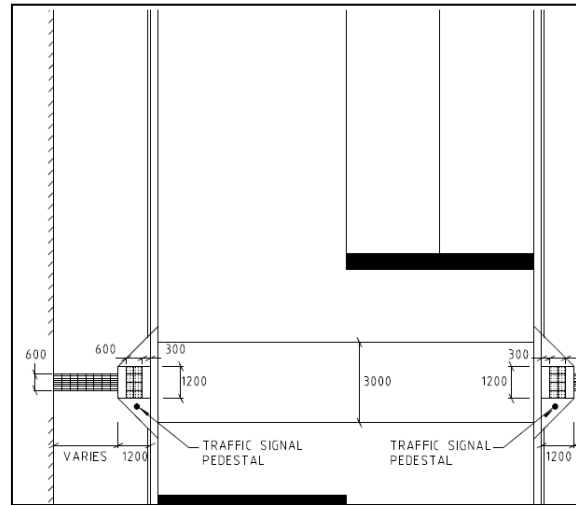

Figure 6 Right Angle Intersection

1:8 kerb ramp gradient

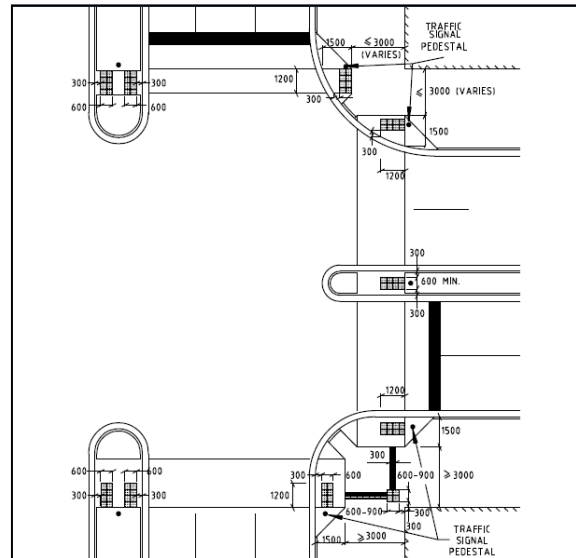

Figure 7 Kerbside

Bus stop without shelter

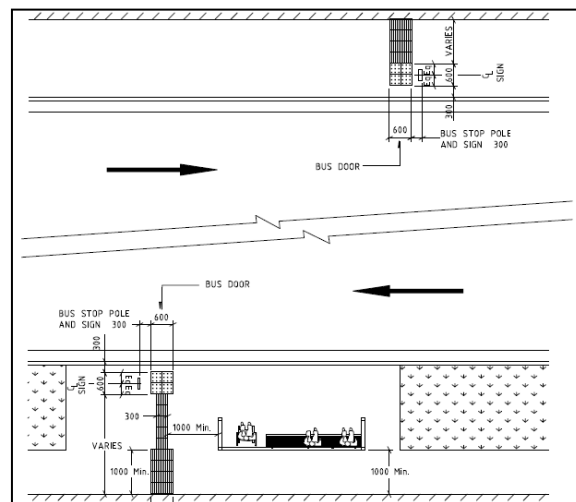

Figure 8 Kerbside

Bus stop/tram light rail with shelter

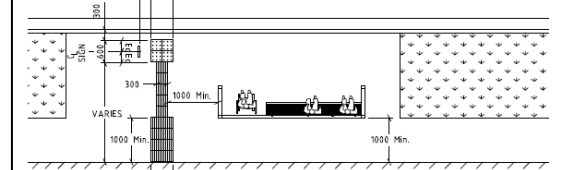

Figure 9 Slip road crossing with raised island

1:8 kerb ramp gradient

The location of the designated crossing point over the slip lane between the footpath and raised island shall be in accordance with best practice and consider pedestrian desire lines in accessing the traffic signals within the raised island.

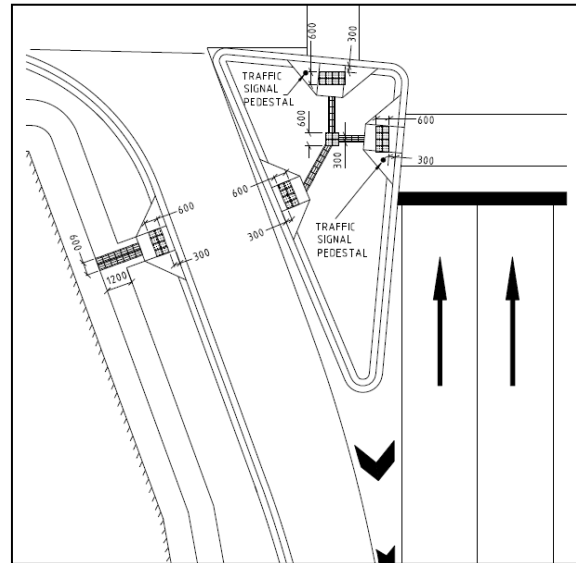

Figure 10 Slip road crossing with raised island

Cut through

The location of the designated crossing point over the slip lane between the footpath and raised island shall be in accordance with best practice and consider pedestrian desire lines in accessing the traffic signals within the raised island.

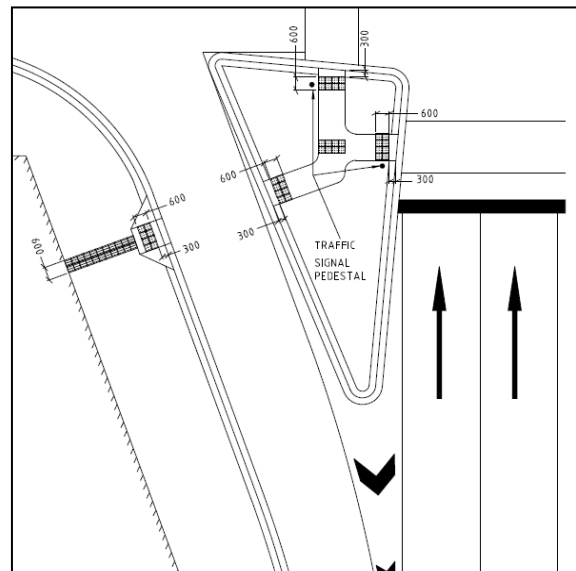

Figure 11 Pedestrian Continuous Accessible Path

Carriageway crossing where motorists vision is limited

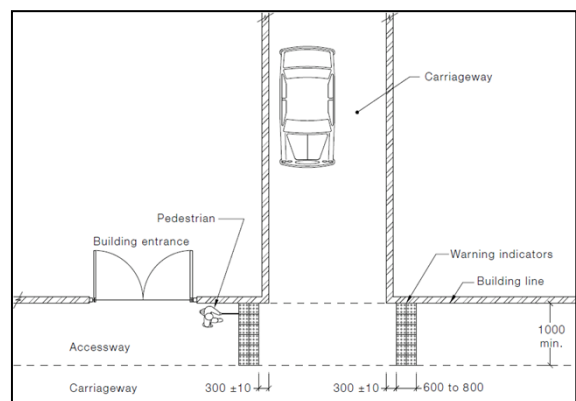

Figure 12 Wombat Type Crossing at Intersection

Examples for $>3000\text{mm}$ to TGS Hazard Pad and
 $<3000\text{mm}$ to TGS Hazard Pad

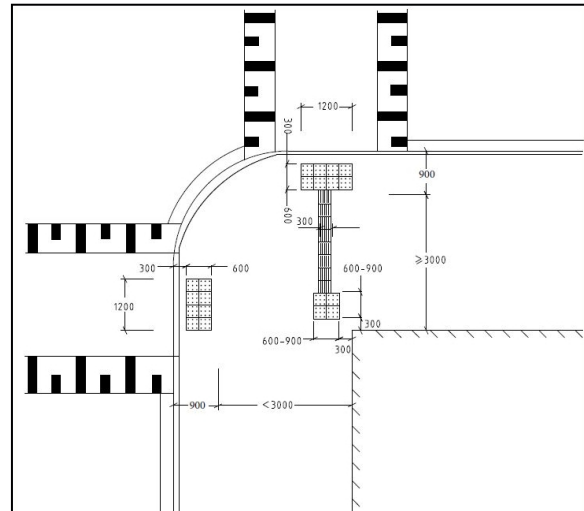
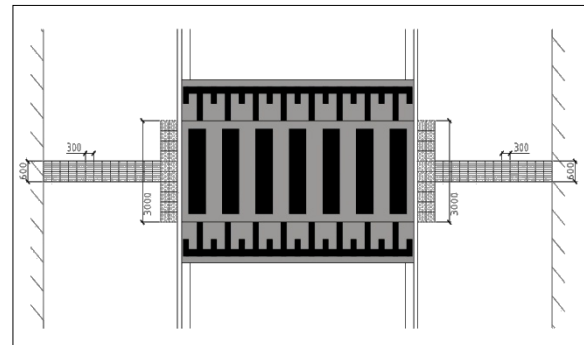

Figure 13 Wombat Crossing Midblock



TGSI required for buildings under BCA

The following figures provide a guide to installing and retrofitting TGSIs to buildings where the installation is abutting the road reserve. The installation of TGSIs and any associated handrail infrastructure must be contained entirely within the title boundary so as not to cause confusion or hazards for vision impaired pedestrians using the road reserve.

AS1428.1 Clause 10.3(f) specifically requires that Where the intersection is at the property boundary, the ramp shall be set back by a minimum of 900 mm so that the handrail and TGSIs do not protrude into the transverse path (Figure 14). Additional examples are included as Figure 15, Figure 16 and Figure 17 where the title boundary is depicted as a dashed line.

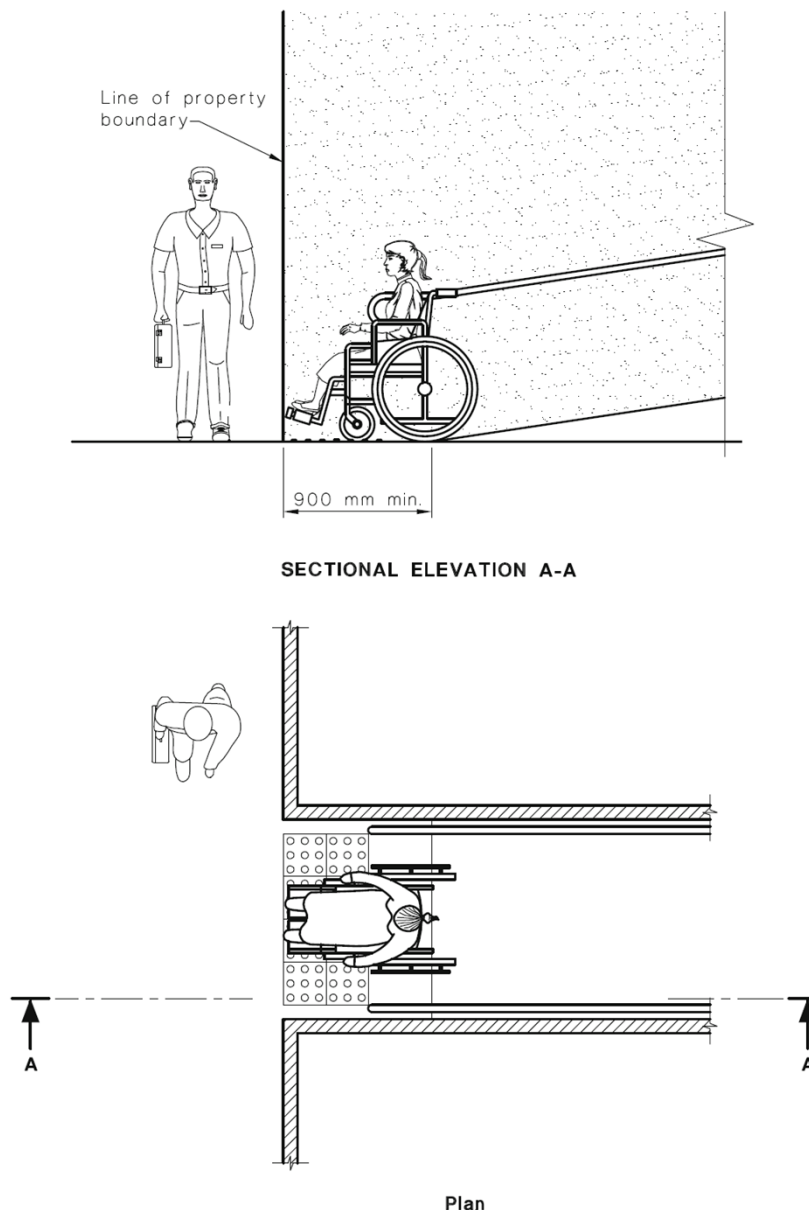

NOTE: TGSIs to be installed within the property boundary.

Figure 14 LOCATION OF RAMP AT A BOUNDARY TO PREVENT PROTRUSION OF HANDRAILS AND TACTILE GROUND SURFACE INDICATORS (TGSIs) INTO A TRANSVERSE PATH OF TRAVEL

Figure 15 Staircase Perpendicular to Title Boundary

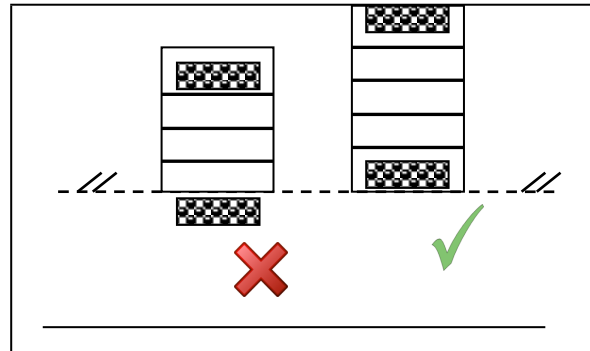

Figure 16 Ramp Parallel to Title Boundary

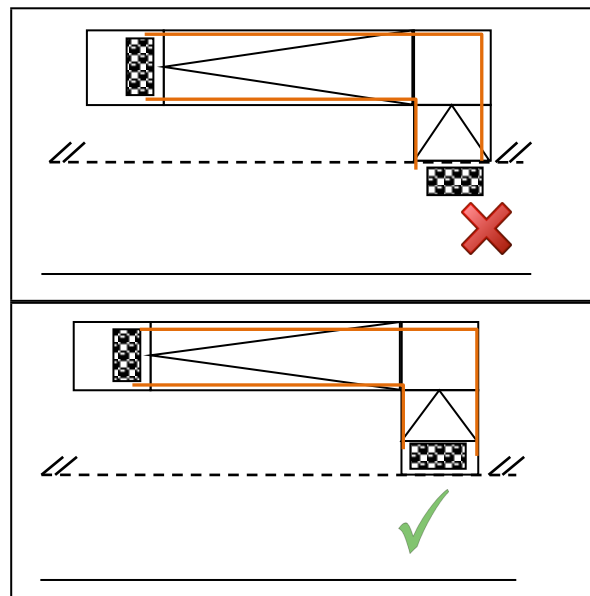
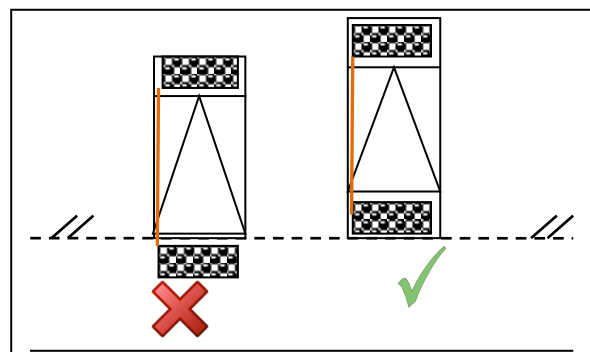

Figure 17 Ramp Perpendicular to Title Boundary



Appendix 1 TGSI Installation Flow Chart

